



RIGOL

DG6000 Series

Function/Arbitrary Waveform Generator

Performance Verification

Feb. 2026

Guaranty and Declaration

Copyright

© 2026 RIGOL TECHNOLOGIES CO., LTD. All Rights Reserved.

Trademark Information

RIGOL® is the trademark of RIGOL TECHNOLOGIES CO., LTD.

Notices

- RIGOL products are covered by P.R.C. and foreign patents, issued and pending.
- RIGOL reserves the right to modify or change parts of or all the specifications and pricing policies at the company's sole decision.
- Information in this publication replaces all previously released materials.
- Information in this publication is subject to change without notice.
- RIGOL shall not be liable for either incidental or consequential losses in connection with the furnishing, use, or performance of this manual, as well as any information contained.
- Any part of this document is forbidden to be copied, photocopied, or rearranged without prior written approval of RIGOL.

Product Certification

RIGOL guarantees that this product conforms to the national and industrial standards in China as well as the ISO9001:2015 standard and the ISO14001:2015 standard. Other international standard conformance certifications are in progress.

Contact Us

If you have any problem or requirement when using our products or this manual, please contact RIGOL.

E-mail: service@rigol.com

Website: <http://www.rigol.com>

Section	Description	Page
1	Safety Requirement	1
1.1	General Safety Summary	1
1.2	Safety Notices and Symbols	3
2	Document Overview	4
3	Overview	5
3.1	Test Preparations	5
3.2	Recommended Test Equipment	5
3.3	Test Considerations	6
3.4	Test Result Record	6
3.5	Specifications	7
4	Performance Verification Test	8
4.1	Frequency Accuracy Test	8
4.1.1	Specification	8
4.1.2	Test Procedures	8
4.1.3	Test Record Form	9
4.2	AC Amplitude Range Accuracy Test	11
4.2.1	Specification	11
4.2.2	Test Procedures	12
4.2.3	Test Record Form	15
4.3	DC Offset Accuracy Test	20
4.3.1	Specification	20
4.3.2	Test Procedures	20
4.3.3	Test Record Form	23
4.4	AC Flatness Test	27
4.4.1	Specification	27
4.4.2	Test Procedures	28
4.4.3	Test Record Form	33
4.5	Harmonic Distortion Test	38
4.5.1	Specification	38
4.5.2	Test Procedures	39
4.5.3	Test Record Form	41
4.6	Spurious Signal Test	47
4.6.1	Specification	47

4.6.2 Test Procedures	47
4.6.3 Test Record Form	49
4.7 Rise/Fall Time Test	51
4.7.1 Specification	51
4.7.2 Test Procedures	52
4.7.3 Test Record Form	53
4.8 Overshoot Test	54
4.8.1 Specification	54
4.8.2 Test Procedures	54
4.8.3 Test Record Form	57
5 Appendix: Test Record Form	61

1 Safety Requirement

1.1 General Safety Summary

Please review the following safety precautions carefully before putting the instrument into operation so as to avoid any personal injury or damage to the instrument and any product connected to it. To prevent potential hazards, please follow the instructions specified in this manual to use the instrument properly.

- **Use the BNC Output Connectors Properly.**

The front-panel BNC output connectors only allow signal output but do not support signal input.

- **Use Proper Power Cord.**

Only the exclusive power cord designed for the instrument and authorized for use within the local country could be used.

- **Ground the Instrument.**

The instrument is grounded through the Protective Earth lead of the power cord. To avoid electric shock, it is essential to connect the earth terminal of the power cord to the Protective Earth terminal before connecting any inputs or outputs.

- **Observe All Terminal Ratings.**

To avoid fire or shock hazard, observe all ratings and markers on the instrument and check your manual for more information about ratings before connecting the instrument.

- **Use Proper Overvoltage Protection.**

Ensure that no overvoltage (such as that caused by a bolt of lightning) can reach the product. Otherwise, the operator might be exposed to the danger of an electric shock.

- **Do Not Operate Without Covers.**

Do not operate the instrument with covers or panels removed.

- **Do Not Insert Objects Into the Air Outlet.**

Do not insert anything into the holes of the fan to avoid damaging the instrument.

- **Use Proper Fuse.**

Please use the specified fuses.

- **Avoid Circuit or Wire Exposure.**

Do not touch exposed junctions and components when the unit is powered on.

- **Do Not Operate With Suspected Failures.**

If you suspect damage occurs to the instrument, have it inspected by RIGOL authorized personnel before further operations. Any maintenance, adjustment or replacement especially to circuits or accessories must be performed by RIGOL authorized personnel.
- **Provide Adequate Ventilation.**

Inadequate ventilation may cause an increase of temperature in the instrument, which would cause damage to the instrument. So please keep the instrument well ventilated and inspect the air outlet and the fan regularly.
- **Do Not Operate in Wet Conditions.**

To avoid short circuit inside the instrument or electric shock, never operate the instrument in a humid environment.
- **Do Not Operate in an Explosive Atmosphere.**

To avoid personal injuries or damage to the instrument, never operate the instrument in an explosive atmosphere.
- **Keep Instrument Surfaces Clean and Dry.**

To avoid dust or moisture from affecting the performance of the instrument, keep the surfaces of the instrument clean and dry.
- **Prevent Electrostatic Impact.**

Operate the instrument in an electrostatic discharge protective environment to avoid damage induced by static discharges. Always ground both the internal and external conductors of cables to release static before making connections.
- **Use the Battery Properly.**

Do not expose the battery (if available) to high temperature or fire. Keep it out of the reach of children. Improper change of a battery (lithium battery) may cause an explosion. Use the RIGOL specified battery only.
- **Handle with Caution.**

Please handle with care during transportation to avoid damage to keys, knobs, interfaces, and other parts on the panels.

**WARNING**

Equipment meeting Class A requirements may not offer adequate protection to broadcast services within residential environment.

1.2 Safety Notices and Symbols

Safety Notices in this Manual:



WARNING

Indicates a potentially hazardous situation or practice which, if not avoided, will result in serious injury or death.



CAUTION

Indicates a potentially hazardous situation or practice which, if not avoided, could result in damage to the product or loss of important data.

Safety Notices on the Product:

- **DANGER**
It calls attention to an operation, if not correctly performed, could result in injury or hazard immediately.
- **WARNING**
It calls attention to an operation, if not correctly performed, could result in potential injury or hazard.
- **CAUTION**
It calls attention to an operation, if not correctly performed, could result in damage to the product or other devices connected to the product.

Safety Symbols on the Product:



Hazardous Voltage



Safety Warning



Protective Earth Terminal

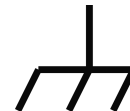

Chassis Ground



Test Ground

2 Document Overview

This manual is designed to guide you to properly test the performance specifications of RIGOL DG6000 Series Function/Arbitrary Waveform Generator. For the operation methods mentioned in the test procedures, refer to User Guide of this product.

Publication Number

PVB19100-1110

Format Conventions in this Manual

1. Key

The front panel key is denoted by the menu key icon. For example,  indicates the "Default" key.

2. Menu

The menu item is denoted by the format of "Menu Name (Bold) + Character Shading" in the manual. For example, **Setup**.

3. Operation Procedures

The next step of the operation is denoted by ">" in the manual. For example, .

> **Utility** indicates first clicking or tapping  and then clicking or tapping **Utility**.

Content Conventions in this Manual

The DG6000 series Function/Arbitrary Waveform Generator includes the following models. Unless otherwise specified, this manual takes DG6104 as an example to illustrate the performance verification methods of the DG6000 series.

Model	No. of Channels	Sample Rate	Max. Output Frequency
DG6052	2	2.5 GSa/s	500 MHz
DG6054	4	2.5 GSa/s	500 MHz
DG6102	2	2.5 GSa/s	1 GHz
DG6104	4	2.5 GSa/s	1 GHz

3 Overview

3.1 Test Preparations

Before the test, please make sure that the instrument is within the calibration period (1 year recommended) and has been operating for at least 30 minutes at a specified operating temperature ($23^{\circ}\text{C}\pm 5^{\circ}\text{C}$).

3.2 Recommended Test Equipment

Use the test equipment listed in the following table to verify the performance of DG6000. If the exact instrument model is not available, it is recommended to select the substitute equipment that can meet the following "Specification".

Table 3.1 Recommended Test Equipment

Equipment	Specification	Recommended Model
Frequency Counter	>10 MHz Accuracy: 0.1 ppm	Agilent 53131A
Digital Multimeter	6½ digits	RIGOL DM3068
Power Meter	-30 dBm to +20 dBm Accuracy: ± 0.02 dB Resolution: 0.01 dB	Agilent E4416A
Spectrum Analyzer	Min. resolution bandwidth ≤ 10 Hz	RIGOL RSA5032
Oscilloscope	Bandwidth: ≥ 2 GHz Rise/Fall time measurement function Overshoot measurement function	Keysight DCA-X 86100D
Power Sensor	-35 dBm to +20 dBm	Agilent N8482A
Power Sensor Cable	Used to connect the power meter and power sensor	-
50 Ω BNC Feed-through Load	50 Ω /1 W	-

Equipment	Specification	Recommended Model
50 Ω SMB Terminated Load	Male connector, used to terminate the unused SMB port	-
Adaptor	N (f)-BNC (m)	-
Adaptor	BNC (f)-N (m)	-
Adaptor	SMB (m)-BNC (m)	-
Adaptor	BNC (f)-Dual Banana Plug (m)	-
Cable	BNC (f)-Single Banana Plug (m)	-
Cable	BNC (m)-BNC (m)	-
Cable	SMB (m)-BNC (m)	-

3.3 Test Considerations

For better performance, all procedures should comply with the following recommendations:

1. Before making the performance verification test, please make sure that the instrument has been operating for at least 30 minutes at a specified operating temperature ($23^{\circ}\text{C}\pm 5^{\circ}\text{C}$).
2. Each test should be performed at the specified operating temperature ($23^{\circ}\text{C}\pm 5^{\circ}\text{C}$).
3. Please reset the instrument to the factory setting before or after executing any of the tests.

3.4 Test Result Record

Record and keep the test result of each test. In the final chapter of this manual, a test result record form is provided. The form lists all the test items and their corresponding performance limits as well as spaces for users to record the test results.



TIP

It is recommended that users photocopy the test record form before each test and record the test results in the copy so that the form can be used repeatedly.

3.5 Specifications

The specification of each test item is provided in this manual. For other technical parameters, refer to *DG6000 Data Sheet* (download it from RIGOL website: www.rigol.com).



TIP

All the specifications are valid only when the instrument has been operating for more than 30 minutes within the specified operating temperature range ($23^{\circ}\text{C}\pm 5^{\circ}\text{C}$).

4 Performance Verification Test

This chapter takes the CH1 of DG6104 as an example to illustrate the performance verification test methods of the DG6000 series. The test method is also applicable to other channels.

4.1 Frequency Accuracy Test

4.1.1 Specification

Frequency Accuracy	
Specification	Typical (1 MHz frequency) $\pm 10^{-6}$ of the setting value (except Arb), 0°C to 50°C $\pm 10^{-6}$ of the setting value $\pm 1 \mu\text{Hz}$ (Arb), 0°C to 50°C

4.1.2 Test Procedures

- As shown in the figure below, use the dual BNC cable to connect the output terminal of DG6000 to the signal input terminal of the frequency counter. This case takes CH1 as an example. The test method also applies to other channels.

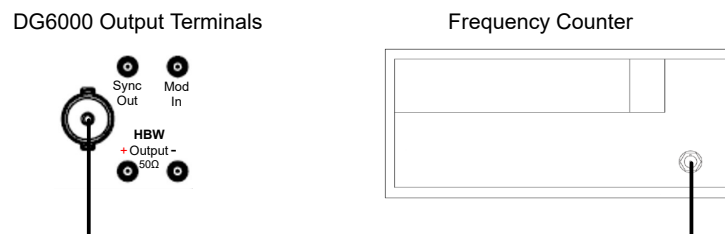

- Set the input impedance of the frequency counter to 1 MΩ.
- Press the front-panel **Default** key of DG6000 and a prompt message is displayed. Click or tap **OK** to restore the instrument to its factory default settings.
- Configure DG6000:
 - Set the output type of CH1 to SND (click or tap  > **Output Type** > **SND**).
 - Set CH1 to output a Sine wave with 1 MHz frequency and 1 Vpp amplitude range.
 - Turn on the output of CH1.

5. Record the current reading on the frequency counter and verify that the reading is between 0.999999 MHz and 1.000001 MHz.
6. Set DG6000 to output Square, Ramp, Pulse, and Harmonics respectively (1 MHz frequency, 1 Vpp amplitude range). Record the reading on the counter respectively and verify that the reading is within 0.999999 MHz and 1.000001 MHz.
7. Repeat the steps above to test the frequency accuracy for other channels and record the test results.

4.1.3 Test Record Form

Frequency Accuracy Test

Channel: CH1

Waveform	Setting	Measured Value	Limit ^[1]	Pass/Fail
Sine	Frequency: 1 MHz Amplitude Range: 1 Vpp		0.999999 MHz to 1.000001 MHz	
Square			0.999999 MHz to 1.000001 MHz	
Ramp			0.999999 MHz to 1.000001 MHz	
Pulse			0.999999 MHz to 1.000001 MHz	
Harmonic			0.999999 MHz to 1.000001 MHz	

Channel: CH2

Waveform	Setting	Measured Value	Limit ^[1]	Pass/Fail
Sine	Frequency: 1 MHz Amplitude Range: 1 Vpp		0.999999 MHz to 1.000001 MHz	
Square			0.999999 MHz to 1.000001 MHz	
Ramp			0.999999 MHz to 1.000001 MHz	
Pulse			0.999999 MHz to 1.000001 MHz	
Harmonic			0.999999 MHz to 1.000001 MHz	

Channel: CH3

Waveform	Setting	Measured Value	Limit ^[1]	Pass/Fail
Sine	Frequency: 1 MHz		0.999999 MHz to 1.000001 MHz	
Square			0.999999 MHz to 1.000001 MHz	

Waveform	Setting	Measured Value	Limit ^[1]	Pass/Fail
Ramp	Amplitude Range: 1 Vpp		0.999999 MHz to 1.000001 MHz	
Pulse			0.999999 MHz to 1.000001 MHz	
Harmonic			0.999999 MHz to 1.000001 MHz	

Channel: CH4

Waveform	Setting	Measured Value	Limit ^[1]	Pass/Fail
Sine	Frequency: 1 MHz Amplitude Range: 1 Vpp		0.999999 MHz to 1.000001 MHz	
Square			0.999999 MHz to 1.000001 MHz	
Ramp			0.999999 MHz to 1.000001 MHz	
Pulse			0.999999 MHz to 1.000001 MHz	
Harmonic			0.999999 MHz to 1.000001 MHz	

Channel: CH5

Waveform	Setting	Measured Value	Limit ^[1]	Pass/Fail
Sine	Frequency: 1 MHz Amplitude Range: 1 Vpp		0.999999 MHz to 1.000001 MHz	
Square			0.999999 MHz to 1.000001 MHz	
Ramp			0.999999 MHz to 1.000001 MHz	
Pulse			0.999999 MHz to 1.000001 MHz	
Harmonic			0.999999 MHz to 1.000001 MHz	

Channel: CH6

Waveform	Setting	Measured Value	Limit ^[1]	Pass/Fail
Sine	Frequency: 1 MHz Amplitude Range: 1 Vpp		0.999999 MHz to 1.000001 MHz	
Square			0.999999 MHz to 1.000001 MHz	
Ramp			0.999999 MHz to 1.000001 MHz	
Pulse			0.999999 MHz to 1.000001 MHz	
Harmonic			0.999999 MHz to 1.000001 MHz	

Channel: CH7

Waveform	Setting	Measured Value	Limit ^[1]	Pass/Fail
Sine	Frequency: 1 MHz Amplitude Range: 1 Vpp		0.999999 MHz to 1.000001 MHz	
Square			0.999999 MHz to 1.000001 MHz	
Ramp			0.999999 MHz to 1.000001 MHz	
Pulse			0.999999 MHz to 1.000001 MHz	
Harmonic			0.999999 MHz to 1.000001 MHz	

Channel: CH8

Waveform	Setting	Measured Value	Limit ^[1]	Pass/Fail
Sine	Frequency: 1 MHz Amplitude Range: 1 Vpp		0.999999 MHz to 1.000001 MHz	
Square			0.999999 MHz to 1.000001 MHz	
Ramp			0.999999 MHz to 1.000001 MHz	
Pulse			0.999999 MHz to 1.000001 MHz	
Harmonic			0.999999 MHz to 1.000001 MHz	

Note^[1]: The limit is calculated from the frequency setting value (1 MHz) \pm permissible error. The permissible error is the setting value of $\pm 10^{-6}$ (except Arb), 0°C to 50°C.

4.2 AC Amplitude Range Accuracy Test

4.2.1 Specification

AC Amplitude Range Accuracy ^[1]	
Specification	SND: $\pm(1\%$ of the setting value + 1 mVpp)(into 50 Ω) HBW: $\pm(1\%$ of the setting value + 1 mVpp)

Note^[1]: For SND output, 1 kHz sine wave, amplitude range > 1 mVpp, 0 V offset, unit: Vpp; for HBW output, 1 kHz sine wave, amplitude range > 400 mVpp, unit: Vpp.

4.2.2 Test Procedures

Test Procedures (SND)

1. As shown in the figure below, connect the 50 Ω BNC feed-through load and the BNC-dual banana adaptor to the voltage input terminal of the multimeter. Then use the BNC cable to connect the 50 Ω load to the output terminal of DG6000. This case takes CH1 as an example. The test method also applies to other channels.

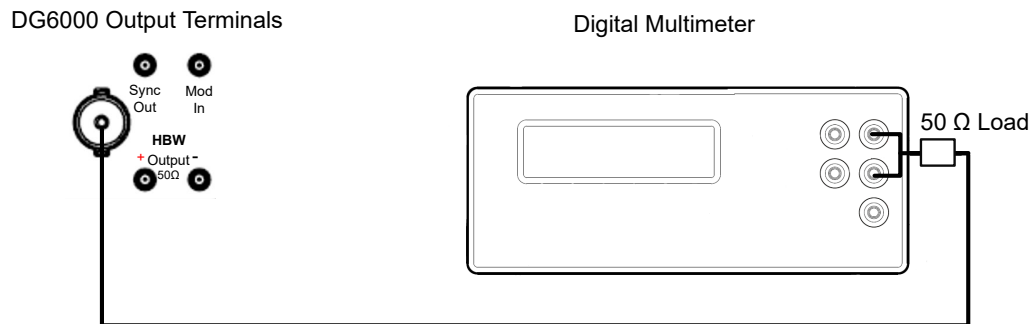

2. Select the AC voltage (ACV) measurement function for the multimeter and set the range to "2 V".
3. Press the front-panel **Default** key of DG6000 and a prompt message is displayed. Click or tap **OK** to restore the instrument to its factory default settings.
4. Configure DG6000:
 - a. Set the output type of CH1 to SND (click or tap  > **Output Type** > **SND**).
 - b. Set the output impedance of CH1 to 50 Ω (in CH1 setup interface, click or tap the **Channel** tab and select "Load" in the drop-down menu of **Imped**).
 - c. Set CH1 to output a Sine wave with 1 kHz frequency, 0 Vdc offset, and 20 mVpp amplitude range.
 - d. Turn on the output of CH1.
5. Record the reading on the multimeter and verify that the reading is within the range specified in the "Limits of Amplitude Range Output Value (Vrms)".
6. Keep other settings unchanged for DG6000 and adjust the output waveform amplitude range of CH1 to 100 mVpp, 500 mVpp, 1 Vpp, 5 Vpp, and 10 Vpp respectively. When the amplitude range of the output waveform is set to 100 mVpp or 500 mVpp, keep the 2 V range for the multimeter; when the amplitude range of the output waveform is set to 1 Vpp, 5 Vpp, or 10 Vpp, set the range to 20 V. Record the reading on the multimeter and verify that the reading is within the range specified in the "Limits of Amplitude Range Output Value (Vrms)".

Amplitude Range Setting (Vpp)	Permissible Error ^[1] (Vpp)	Limits of Amplitude Range Output Value (Vpp)	Limits of Amplitude Range Output Value (Vrms) ^[2]
20 mVpp	±1.2 mV	18.8 mVpp to 21.2 mVpp	6.6 mVrms to 7.5 mVrms
100 mVpp	±2 mV	98 mVpp to 102 mVpp	34.6 mVrms to 36.1 mVrms
500 mVpp	±6 mV	494 mVpp to 506 mVpp	174.7 mVrms to 178.9 mVrms
1 Vpp	±11 mV	0.989 Vpp to 1.011 Vpp	349.7 mVrms to 357.4 mVrms
5 Vpp	±51 mV	4.949 Vpp to 5.051 Vpp	1.7497 Vrms to 1.7857 Vrms
10 Vpp	±101 mV	9.899 Vpp to 10.101 Vpp	3.4998 Vrms to 3.5712 Vrms

Note^[1]: "Permissible Error" is calculated from the specification "±(1% of the setting value + 1 mVpp)".

Note^[2]: "Limits of Amplitude Range Output Value (Vrms)" is calculated from "Limits of Amplitude Range Output Value (Vpp)". The conversion relationship between Vrms and Vpp: $V_{pp} = 2\sqrt{2} V_{rms}$.

7. Repeat the steps above to test the amplitude range accuracy for other channels and record the test results.

Test Procedures (HBW)

1. As shown in the figure below, connect the SMB-BNC adaptor and the 50 Ω BNC feed-through load to the CH1 (+) port of DG6000 and use the BNC-single banana plug cable to connect the 50 Ω load and the voltage input terminal (HI) of the digital multimeter. Connect the SMB-BNC adaptor and the 50 Ω BNC feed-through load to the CH1 (-) port of DG6000 and use the BNC-single banana plug cable to connect the 50 Ω load and the voltage input terminal (LO) of the digital multimeter. This case takes CH1 as an example. The test method also applies to other channels.

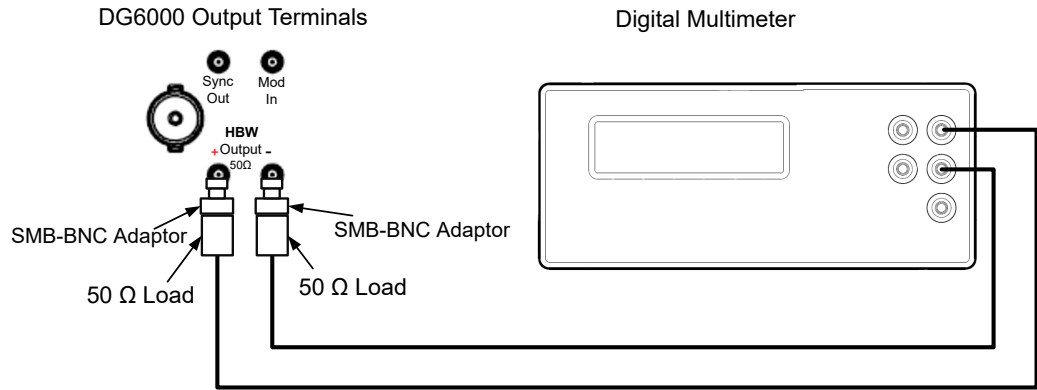

2. Select the AC voltage (ACV) measurement function for the multimeter and set the range to "2 V".
3. Press the front-panel Default key of DG6000 and a prompt message is displayed. Click or tap **OK** to restore the instrument to its factory default settings.
4. Configure DG6000:
 - a. Set the output type of CH1 to HBW (click or tap > **Output Type** > **HBW**).
 - b. Set CH1 to output a Sine wave with 1 kHz frequency and 400 mVpp amplitude range.
 - c. Turn on the output of CH1.
5. Record the reading on the multimeter and verify that the reading is within the range specified in the "Limits of Amplitude Range Output Value (Vrms)".
6. Keep other settings unchanged for DG6000 and adjust the output waveform amplitude range of CH1 to 1 Vpp, 1.4 Vpp, and 2 Vpp respectively. Set the range of the multimeter to 20 V. Record the reading on the multimeter and verify that the reading is within the range specified in the "Limits of Amplitude Range Output Value (Vrms)".

Amplitude Range Setting (Vpp)	Permissible Error ^[1] (Vpp)	Limits of Amplitude Range Output Value (Vpp)	Limits of Amplitude Range Output Value (Vrms) ^[2]
400 mVpp	±5 mV	395 mVpp to 405 mVpp	139.7 mVrms to 143.2 mVrms
1 Vpp	±11 mV	0.989 Vpp to 1.011 Vpp	349.7 mVrms to 357.4 mVrms
1.4 Vpp	±15 mV	1.385 Vpp to 1.415 Vpp	489.7 mVrms to 500.3 mVrms

Amplitude Range Setting (Vpp)	Permissible Error ^[1] (Vpp)	Limits of Amplitude Range Output Value (Vpp)	Limits of Amplitude Range Output Value (Vrms) ^[2]
2 Vpp	±21 mV	1.979 Vpp to 2.021 Vpp	699.7 mVrms to 714.5 mVrms

Note^[1]: "Permissible Error" is calculated from the specification "±(1% of the setting value + 1 mVpp)".

Note^[2]: "Limits of Amplitude Range Output Value (Vrms)" is calculated from "Limits of Amplitude Range Output Value (Vpp)". The conversion relationship between Vrms and Vpp: $V_{pp} = 2\sqrt{2} V_{rms}$.

- Repeat the steps above to test the amplitude range accuracy for other channels and record the test results.

4.2.3 Test Record Form

AC Amplitude Range Accuracy Test (SND)

Channel: CH1

Amplitude Range Setting	Setting	Measured Value	Limit ^[1]	Pass/Fail
20 mVpp	Frequency: 1 kHz Offset: 0 Vdc Impedance: 50 Ω		6.6 mVrms to 7.5 mVrms	
100 mVpp			34.6 mVrms to 36.1 mVrms	
500 mVpp			174.7 mVrms to 178.9 mVrms	
1 Vpp			349.7 mVrms to 357.4 mVrms	
5 Vpp			1.7497Vrms to 1.7857 Vrms	
10 Vpp			3.4998 mVrms to 3.5712 mVrms	

Channel: CH2

Amplitude Range Setting	Setting	Measured Value	Limit ^[1]	Pass/Fail
20 mVpp	Frequency: 1 kHz		6.6 mVrms to 7.5 mVrms	

Amplitude Range Setting	Setting	Measured Value	Limit ^[1]	Pass/Fail
100 mVpp	Offset: 0 Vdc Impedance: 50 Ω		34.6 mVrms to 36.1 mVrms	
500 mVpp			174.7 mVrms to 178.9 mVrms	
1 Vpp			349.7 mVrms to 357.4 mVrms	
5 Vpp			1.7497Vrms to 1.7857 Vrms	
10 Vpp			3.4998 mVrms to 3.5712 mVrms	

Channel: CH3

Amplitude Range Setting	Setting	Measured Value	Limit ^[1]	Pass/Fail
20 mVpp	Frequency: 1 kHz Offset: 0 Vdc Impedance: 50 Ω		6.6 mVrms to 7.5 mVrms	
100 mVpp			34.6 mVrms to 36.1 mVrms	
500 mVpp			174.7 mVrms to 178.9 mVrms	
1 Vpp			349.7 mVrms to 357.4 mVrms	
5 Vpp			1.7497Vrms to 1.7857 Vrms	
10 Vpp			3.4998 mVrms to 3.5712 mVrms	

Channel: CH4

Amplitude Range Setting	Setting	Measured Value	Limit ^[1]	Pass/Fail
20 mVpp	Frequency: 1 kHz Offset: 0 Vdc Impedance: 50 Ω		6.6 mVrms to 7.5 mVrms	
100 mVpp			34.6 mVrms to 36.1 mVrms	
500 mVpp			174.7 mVrms to 178.9 mVrms	

Amplitude Range Setting	Setting	Measured Value	Limit ^[1]	Pass/Fail
1 Vpp			349.7 mVrms to 357.4 mVrms	
5 Vpp			1.7497Vrms to 1.7857 Vrms	
10 Vpp			3.4998 mVrms to 3.5712 mVrms	

Channel: CH5

Amplitude Range Setting	Setting	Measured Value	Limit ^[1]	Pass/Fail
20 mVpp	Frequency: 1 kHz Offset: 0 Vdc Impedance: 50 Ω		6.6 mVrms to 7.5 mVrms	
100 mVpp			34.6 mVrms to 36.1 mVrms	
500 mVpp			174.7 mVrms to 178.9 mVrms	
1 Vpp			349.7 mVrms to 357.4 mVrms	
5 Vpp			1.7497Vrms to 1.7857 Vrms	
10 Vpp			3.4998 mVrms to 3.5712 mVrms	

Channel: CH6

Amplitude Range Setting	Setting	Measured Value	Limit ^[1]	Pass/Fail
20 mVpp	Frequency: 1 kHz Offset: 0 Vdc Impedance: 50 Ω		6.6 mVrms to 7.5 mVrms	
100 mVpp			34.6 mVrms to 36.1 mVrms	
500 mVpp			174.7 mVrms to 178.9 mVrms	
1 Vpp			349.7 mVrms to 357.4 mVrms	
5 Vpp			1.7497Vrms to 1.7857 Vrms	

Amplitude Range Setting	Setting	Measured Value	Limit ^[1]	Pass/Fail
10 Vpp			3.4998 mVrms to 3.5712 mVrms	

Channel: CH7

Amplitude Range Setting	Setting	Measured Value	Limit ^[1]	Pass/Fail
20 mVpp	Frequency: 1 kHz Offset: 0 Vdc Impedance: 50 Ω		6.6 mVrms to 7.5 mVrms	
100 mVpp			34.6 mVrms to 36.1 mVrms	
500 mVpp			174.7 mVrms to 178.9 mVrms	
1 Vpp			349.7 mVrms to 357.4 mVrms	
5 Vpp			1.7497Vrms to 1.7857 Vrms	
10 Vpp			3.4998 mVrms to 3.5712 mVrms	

Channel: CH8

Amplitude Range Setting	Setting	Measured Value	Limit ^[1]	Pass/Fail
20 mVpp	Frequency: 1 kHz Offset: 0 Vdc Impedance: 50 Ω		6.6 mVrms to 7.5 mVrms	
100 mVpp			34.6 mVrms to 36.1 mVrms	
500 mVpp			174.7 mVrms to 178.9 mVrms	
1 Vpp			349.7 mVrms to 357.4 mVrms	
5 Vpp			1.7497Vrms to 1.7857 Vrms	
10 Vpp			3.4998 mVrms to 3.5712 mVrms	

Note^[1]: 1 kHz Sine, amplitude range > 1 mVpp, 0 Vdc offset, unit: Vpp. $\pm(1\%$ of the setting value + 1 mVpp).

AC Amplitude Range Accuracy Test (HBW)

Channel: CH1

Amplitude Range Setting	Setting	Measured Value	Limit ^[1]	Pass/Fail
400 mVpp	Frequency: 1 kHz Impedance: 50 Ω		6.6 mVrms to 7.5 mVrms	
1 Vpp			34.6 mVrms to 36.1 mVrms	
1.4 Vpp			174.7 mVrms to 178.9 mVrms	
2 Vpp			349.7 mVrms to 357.4 mVrms	

Channel: CH2

Amplitude Range Setting	Setting	Measured Value	Limit ^[1]	Pass/Fail
400 mVpp	Frequency: 1 kHz Impedance: 50 Ω		6.6 mVrms to 7.5 mVrms	
1 Vpp			34.6 mVrms to 36.1 mVrms	
1.4 Vpp			174.7 mVrms to 178.9 mVrms	
2 Vpp			349.7 mVrms to 357.4 mVrms	

Channel: CH3

Amplitude Range Setting	Setting	Measured Value	Limit ^[1]	Pass/Fail
400 mVpp	Frequency: 1 kHz Impedance: 50 Ω		6.6 mVrms to 7.5 mVrms	
1 Vpp			34.6 mVrms to 36.1 mVrms	
1.4 Vpp			174.7 mVrms to 178.9 mVrms	
2 Vpp			349.7 mVrms to 357.4 mVrms	

Channel: CH4

Amplitude Range Setting	Setting	Measured Value	Limit ^[1]	Pass/Fail
400 mVpp	Frequency: 1 kHz Impedance: 50 Ω		6.6 mVrms to 7.5 mVrms	
1 Vpp			34.6 mVrms to 36.1 mVrms	
1.4 Vpp			174.7 mVrms to 178.9 mVrms	
2 Vpp			349.7 mVrms to 357.4 mVrms	

Note^[1]: 1 kHz Sine, amplitude range > 400 mVpp, unit: Vpp. ±(1% of the setting value + 1 mVpp).

4.3 DC Offset Accuracy Test

4.3.1 Specification

DC Offset Accuracy	
Specification	SND: ±(1% of setting value + 1 mV + 0.5% of amplitude range (Vpp))(into 50 Ω) HBW: ±(1% of setting value + 5 mV)

4.3.2 Test Procedures

Test Procedures (SND)

- As shown in the figure below, connect the 50 Ω BNC feed-through load and the BNC-dual banana adaptor to the voltage input terminal of the multimeter. Then use the BNC cable to connect the 50 Ω load to the output terminal of DG6000. This case takes CH1 as an example. The test method also applies to other channels.

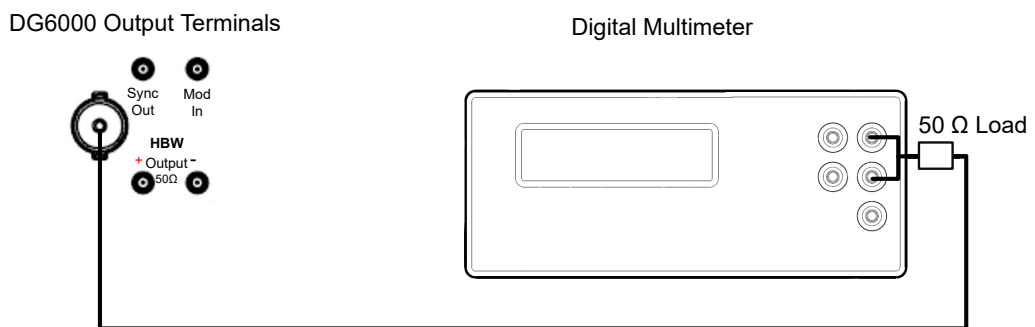

2. Select the DC voltage (DCV) measurement function for the multimeter and set the range to 20 V.
3. Press the front-panel Default key of DG6000 and a prompt message is displayed. Click or tap **OK** to restore the instrument to its factory default settings.
4. Configure DG6000:
 - a. Set the output type of CH1 to SND (click or tap  > **Output Type** > **SND**).
 - b. Set the output impedance of CH1 to 50 Ω (in CH1 setup interface, click or tap the **Channel** tab and select "Load" in the drop-down menu of **Imped**).
 - c. Set CH1 to output a Sine wave with 1 kHz frequency, 5 Vpp amplitude range, and 0 Vdc offset.
 - d. Turn on the output of CH1.
5. Record the reading on the multimeter and verify that the reading is within the range specified in the "Offset Limit" of the table below.
6. Keep the other settings unchanged and adjust the output waveform offset of CH1 to -2.5 Vdc, -1 Vdc, -500 mVdc, 500 mVdc, 1 Vdc, and 2.5 Vdc respectively. Record the reading on the multimeter and verify that the reading is within the "Offset Limit" specified in the table below.

Offset Setting	Amplitude Range Setting	Permissible Error ^[1]	Offset Limit
-2.5 Vdc	5 Vpp	± 0.051 Vdc	-2.551 Vdc to -2.449 Vdc
-1 Vdc		± 0.036 Vdc	-1.036 Vdc to -0.964 Vdc
-500 mVdc		± 0.031 Vdc	-0.531 Vdc to -0.469 Vdc
0 Vdc		± 0.026 Vdc	-0.026 Vdc to +0.026 Vdc
+500 mVdc		± 0.031 Vdc	0.469 Vdc to 0.531 Vdc
+1 Vdc		± 0.036 Vdc	0.964 Vdc to 1.036 Vdc
+2.5 Vdc		± 0.051 Vdc	2.449 Vdc to 2.551 Vdc

Note^[1]: "Permissible Error" is calculated from the specification " $\pm(1\%$ of |the setting value| + 1 mV + 0.5% of the amplitude (Vpp))".

7. Repeat the steps above to verify the DC offset accuracy for other channels and record the test results.

Test Procedures (HBW)

1. As shown in the figure below, use the SMB -BNC cable to connect the CH1 (+) port of DG6000 to the voltage input terminal of the oscilloscope. This case takes CH1 as an example. The test method also applies to other channels.

DG6000 Output Terminals

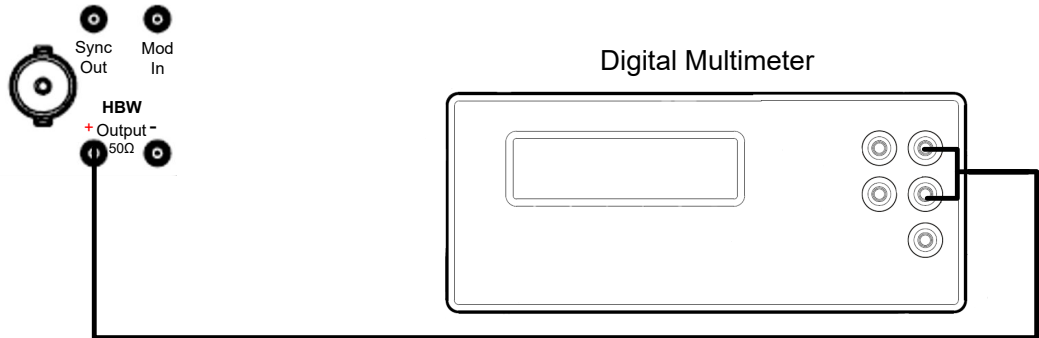

2. Select the DC voltage (DCV) measurement function for the multimeter and set the range to 0.2 V.
3. Press the front-panel **Default** key of DG6000 and a prompt message is displayed. Click or tap **OK** to restore the instrument to its factory default settings.
4. Configure DG6000:
 - a. Set the output type of CH1 to HBW (click or tap > **Output Type** > **HBW**).
 - b. Set CH1 to output a Sine wave with 1 kHz frequency, 100 mVpp amplitude range, and 0 Vdc offset.
 - c. Turn on the output of CH1.
5. Record the reading on the multimeter and verify that the reading is within the range specified in the "Offset Limit" of the table below.
6. Keep the other settings unchanged and adjust the output waveform offset of CH1 to -200 mVdc, -100 mVdc, 0 Vdc, +100 mVdc, and +200 mVdc respectively. Record the reading on the multimeter and verify that the reading is within the "Offset Limit" specified in the table below.

Offset Setting	Amplitude Range Setting	Permissible Error ^[1]	Offset Limit
-200 mVdc	1 Vpp	±7 mVdc	-207 mVdc to -193 mVdc
-100 mVdc		±6 mVdc	-106 mVdc to -94 mVdc
0 Vdc		±5 mVdc	-5 mVdc to +5 mVdc
+100 mVdc		±6 mVdc	+94 mVdc to +106 mVdc

Offset Setting	Amplitude Range Setting	Permissible Error ^[1]	Offset Limit
+200 mVdc		±7 mVdc	+193 mVdc to +207 mVdc

Note^[1]: "Permissible Error" is calculated from the specification " $\pm(1\% \text{ of } |\text{setting value}| + 5 \text{ mV})$ ".

- Repeat the steps above to verify the DC offset accuracy for other channels and record the test results.

4.3.3 Test Record Form

DC Offset Accuracy Test (SND)

Channel: CH1

Offset Setting	Setting	Measured Value	Limit ^[1]	Pass/Fail
-2.5 Vdc	Frequency: 1 kHz Amplitude Range: 5 Vpp Impedance: 50 Ω		-2.551 Vdc to -2.449 Vdc	
-1 Vdc			-1.036 Vdc to -0.964 Vdc	
-500 mVdc			-0.531 Vdc to -0.469 Vdc	
0 Vdc			-0.026 Vdc to +0.026 Vdc	
+500 mVdc			0.469 Vdc to 0.531 Vdc	
+1 Vdc			0.964 Vdc to 1.036 Vdc	
+2.5 Vdc			2.449 Vdc to 2.551 Vdc	

Channel: CH2

Offset Setting	Setting	Measured Value	Limit ^[1]	Pass/Fail
-2.5 Vdc	Frequency: 1 kHz Amplitude Range: 5 Vpp Impedance: 50 Ω		-2.551 Vdc to -2.449 Vdc	
-1 Vdc			-1.036 Vdc to -0.964 Vdc	
-500 mVdc			-0.531 Vdc to -0.469 Vdc	
0 Vdc			-0.026 Vdc to +0.026 Vdc	
+500 mVdc			0.469 Vdc to 0.531 Vdc	
+1 Vdc			0.964 Vdc to 1.036 Vdc	

Offset Setting	Setting	Measured Value	Limit ^[1]	Pass/Fail
+2.5 Vdc			2.449 Vdc to 2.551 Vdc	

Channel: CH3

Offset Setting	Setting	Measured Value	Limit ^[1]	Pass/Fail
-2.5 Vdc	Frequency: 1 kHz Amplitude Range: 5 Vpp Impedance: 50 Ω		-2.551 Vdc to -2.449 Vdc	
-1 Vdc			-1.036 Vdc to -0.964 Vdc	
-500 mVdc			-0.531 Vdc to -0.469 Vdc	
0 Vdc			-0.026 Vdc to +0.026 Vdc	
+500 mVdc			0.469 Vdc to 0.531 Vdc	
+1 Vdc			0.964 Vdc to 1.036 Vdc	
+2.5 Vdc			2.449 Vdc to 2.551 Vdc	

Channel: CH4

Offset Setting	Setting	Measured Value	Limit ^[1]	Pass/Fail
-2.5 Vdc	Frequency: 1 kHz Amplitude Range: 5 Vpp Impedance: 50 Ω		-2.551 Vdc to -2.449 Vdc	
-1 Vdc			-1.036 Vdc to -0.964 Vdc	
-500 mVdc			-0.531 Vdc to -0.469 Vdc	
0 Vdc			-0.026 Vdc to +0.026 Vdc	
+500 mVdc			0.469 Vdc to 0.531 Vdc	
+1 Vdc			0.964 Vdc to 1.036 Vdc	
+2.5 Vdc			2.449 Vdc to 2.551 Vdc	

Channel: CH5

Offset Setting	Setting	Measured Value	Limit ^[1]	Pass/Fail
-2.5 Vdc	Frequency: 1 kHz Amplitude Range: 5 Vpp		-2.551 Vdc to -2.449 Vdc	
-1 Vdc			-1.036 Vdc to -0.964 Vdc	
-500 mVdc			-0.531 Vdc to -0.469 Vdc	

Offset Setting	Setting	Measured Value	Limit ^[1]	Pass/Fail
0 Vdc	Impedance: 50 Ω		-0.026 Vdc to +0.026 Vdc	
+500 mVdc			0.469 Vdc to 0.531 Vdc	
+1 Vdc			0.964 Vdc to 1.036 Vdc	
+2.5 Vdc			2.449 Vdc to 2.551 Vdc	

Channel: CH6

Offset Setting	Setting	Measured Value	Limit ^[1]	Pass/Fail
-2.5 Vdc	Frequency: 1 kHz Amplitude Range: 5 Vpp Impedance: 50 Ω		-2.551 Vdc to -2.449 Vdc	
-1 Vdc			-1.036 Vdc to -0.964 Vdc	
-500 mVdc			-0.531 Vdc to -0.469 Vdc	
0 Vdc			-0.026 Vdc to +0.026 Vdc	
+500 mVdc			0.469 Vdc to 0.531 Vdc	
+1 Vdc			0.964 Vdc to 1.036 Vdc	
+2.5 Vdc			2.449 Vdc to 2.551 Vdc	

Channel: CH7

Offset Setting	Setting	Measured Value	Limit ^[1]	Pass/Fail
-2.5 Vdc	Frequency: 1 kHz Amplitude Range: 5 Vpp Impedance: 50 Ω		-2.551 Vdc to -2.449 Vdc	
-1 Vdc			-1.036 Vdc to -0.964 Vdc	
-500 mVdc			-0.531 Vdc to -0.469 Vdc	
0 Vdc			-0.026 Vdc to +0.026 Vdc	
+500 mVdc			0.469 Vdc to 0.531 Vdc	
+1 Vdc			0.964 Vdc to 1.036 Vdc	
+2.5 Vdc			2.449 Vdc to 2.551 Vdc	

Channel: CH8

Offset Setting	Setting	Measured Value	Limit ^[1]	Pass/Fail
-2.5 Vdc	Frequency: 1 kHz Amplitude Range: 5 Vpp Impedance: 50 Ω		-2.551 Vdc to -2.449 Vdc	
-1 Vdc			-1.036 Vdc to -0.964 Vdc	
-500 mVdc			-0.531 Vdc to -0.469 Vdc	
0 Vdc			-0.026 Vdc to +0.026 Vdc	
+500 mVdc			0.469 Vdc to 0.531 Vdc	
+1 Vdc			0.964 Vdc to 1.036 Vdc	
+2.5 Vdc			2.449 Vdc to 2.551 Vdc	

Note^[1]: The offset limit value is calculated from the offset setting value \pm permissible error. The permissible error is calculated from the specification " $\pm(1\%$ of |the setting value| + 1 mVdc + 0.5% of the amplitude (Vpp))".

DC Offset Accuracy Test (HBW)

Channel: CH1

Offset Setting	Amplitude Range Setting	Permissible Error ^[1]	Offset Limit
-200 mVdc	1 Vpp	± 7 mVdc	-207 mVdc to -193 mVdc
-100 mVdc		± 6 mVdc	-106 mVdc to -94 mVdc
0 Vdc		± 5 mVdc	-5 mVdc to +5 mVdc
+100 mVdc		± 6 mVdc	+94 mVdc to +106 mVdc
+200 mVdc		± 7 mVdc	+193 mVdc to +207 mVdc

Channel: CH2

Offset Setting	Amplitude Range Setting	Permissible Error ^[1]	Offset Limit
-200 mVdc	1 Vpp	± 7 mVdc	-207 mVdc to -193 mVdc
-100 mVdc		± 6 mVdc	-106 mVdc to -94 mVdc
0 Vdc		± 5 mVdc	-5 mVdc to +5 mVdc
+100 mVdc		± 6 mVdc	+94 mVdc to +106 mVdc
+200 mVdc		± 7 mVdc	+193 mVdc to +207 mVdc

Channel: CH3

Offset Setting	Amplitude Range Setting	Permissible Error ^[1]	Offset Limit
-200 mVdc	1 Vpp	±7 mVdc	-207 mVdc to -193 mVdc
-100 mVdc		±6 mVdc	-106 mVdc to -94 mVdc
0 Vdc		±5 mVdc	-5 mVdc to +5 mVdc
+100 mVdc		±6 mVdc	+94 mVdc to +106 mVdc
+200 mVdc		±7 mVdc	+193 mVdc to +207 mVdc

Channel: CH4

Offset Setting	Amplitude Range Setting	Permissible Error ^[1]	Offset Limit
-200 mVdc	1 Vpp	±7 mVdc	-207 mVdc to -193 mVdc
-100 mVdc		±6 mVdc	-106 mVdc to -94 mVdc
0 Vdc		±5 mVdc	-5 mVdc to +5 mVdc
+100 mVdc		±6 mVdc	+94 mVdc to +106 mVdc
+200 mVdc		±7 mVdc	+193 Vdc to +207 mVdc

Note^[1]: The offset limit value is calculated from the offset setting value \pm permissible error. The permissible error is calculated from the specification " $\pm(1\% \text{ of } |\text{the setting value}| + 5 \text{ mV})$ ".

4.4 AC Flatness Test

4.4.1 Specification

AC Flatness	
Flatness	Typical ^[1] <5 MHz: ± 0.1 dB ≥ 5 MHz to <50 MHz: ± 0.2 dB ≥ 50 MHz to <100 MHz: ± 0.5 dB ≥ 100 MHz to <200 MHz: ± 1.0 dB ≥ 200 MHz to 1000 MHz: ± 2.0 dB

[1]: 1 μ Hz to 200 kHz relative to 1 kHz Sine, >200 kHz relative to 1 MHz Sine; 0 dBm amplitude range.

4.4.2 Test Procedures

Test Procedures (SND)

AC flatness testing is divided into a low-frequency range (≤ 200 kHz) and a high-frequency range (> 200 kHz). The low-frequency range is measured with a digital multimeter (DMM), while the high-frequency range is measured with a power meter.

1. As shown in the figure below, connect the 50 Ω BNC feed-through load and the BNC-dual banana adaptor to the voltage input terminal of the multimeter. Then use the BNC cable to connect the 50 Ω load to the output terminal of DG6000. This case takes CH1 as an example. The test method also applies to other channels.

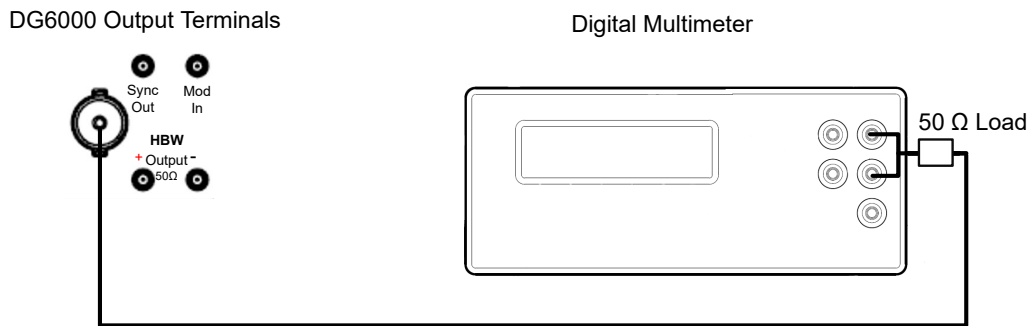



2. Press the front-panel **Default** key of DG6000 and a prompt message is displayed. Click or tap **OK** to restore the instrument to its factory default settings.
3. Configure DG6000:
 - a. Set the output type of CH1 to SND (click or tap  > **Output Type** > **SND**).
 - b. Set the output impedance of CH1 to 50 Ω (in CH1 setup interface, click or tap the **Channel** tab and select "Load" in the drop-down menu of **Imped**).
 - c. Set CH1 to output a Sine wave with 1 kHz frequency and 0 dBm amplitude range.
 - d. Turn on the output of CH1.
4. Select the AC voltage measurement function for the multimeter and enable the dBm operation. Set the reference resistance to 50 Ω and read the measured value as the low-frequency range reference power value (P_{ref1}).



TIP

In this step, if the dBm operation is not enabled, you can also use the measured value ($V_{Reading}$) on the multimeter and the formula " $\text{dBm} = 10 \times \lg[(V_{Reading}^2/R_{ref})/1 \text{ mW}]$ " to calculate the reference power value; wherein, R_{ref} is the load impedance.

5. Keep other settings unchanged for DG6000 and adjust the output frequency to 100 kHz. Record the measured value and verify that the "Measured Value- P_{ref1} " is between -0.1 dB and +0.1 dB.
6. Calibrate the power meter:
 - a. Press the front-panel  key of the power sensor to restore the power sensor to its factory defaults.
 - b. Connect the power sensor to the input terminal and the [POWER REF] terminal of the power meter respectively.
 - c. Press the  key to open the Zero/Cal menu. Click or tap **Zero+Cal** to perform the calibration. After the calibration is complete, observe whether the measured value of the power meter is 0 dBm, 50 MHz.
7. Disconnect DG6000 and the multimeter. Use the N-BNC adaptor to connect the power sensor to the output terminal of DG6000. This case takes CH1 as an example. The test method also applies to other channels. Use the power meter cable to connect the power sensor output terminal to the power meter input terminal, as shown in the figure below.

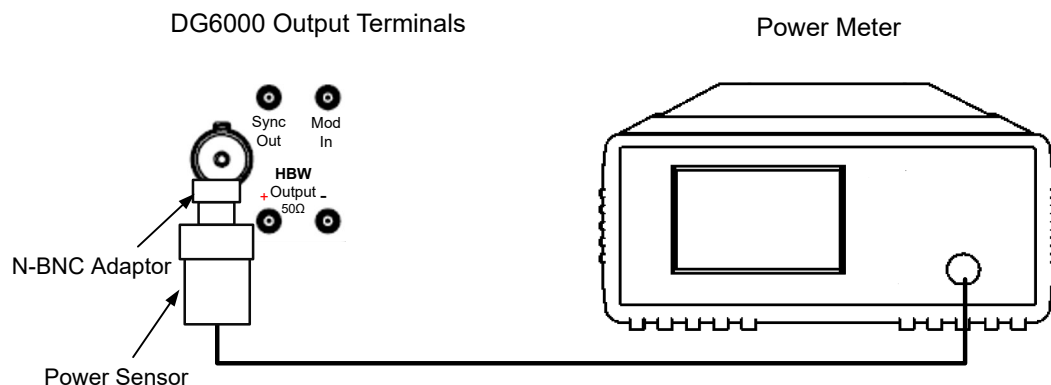

8. Keep other settings unchanged for DG6000 and adjust the output frequency to 1 MHz. Set the center frequency of the power meter to 1 MHz. Record the measured value of the power meter as the high-frequency range reference power value (P_{ref2}).
9. Keep other settings unchanged for DG6000 and adjust the output frequency to 2 MHz. Set the center frequency to 2 MHz for the power meter. Record the measured value and verify that the "Measured Value- P_{ref2} " is between -0.1 dB and +0.1 dB.
10. Keep other settings unchanged for DG6000 and adjust the output frequency to 5 MHz. Set the center frequency to 5 MHz for the power meter. Record the measured value and verify that the "Measured Value- P_{ref2} " is between -0.2 dB and +0.2 dB.

11. Keep other settings unchanged for DG6000 and adjust the output frequency to 50 MHz. Set the center frequency to 50 MHz for the power meter. Record the measured value and verify that the "Measured Value- P_{ref2} " is between -0.5 dB and +0.5 dB.
12. Keep other settings unchanged for DG6000 and adjust the output frequency to 100 MHz. Set the center frequency to 100 MHz for the power meter. Record the measured value and verify that the "Measured Value- P_{ref2} " is between -1.0 dB and +1.0 dB.
13. Keep other settings unchanged for DG6000 and adjust the output frequency to 200 MHz. Set the center frequency to 200 MHz for the power meter. Record the measured value and verify that the "Measured Value- P_{ref2} " is between -2.0 dB and +2.0 dB.
14. Keep other settings unchanged for DG6000 and adjust the output frequency to 500 MHz (DG6102/DG6104 only). Set the center frequency to 500 MHz for the power meter. Record the measured value and verify that the "Measured Value- P_{ref2} " is between -2.0 dB and +2.0 dB.
15. Repeat the steps above to verify the AC flatness for other channels and record the test results.

Test Procedures (HBW)

AC flatness testing is divided into a low-frequency range (≤ 200 kHz) and a high-frequency range (> 200 kHz). The low-frequency range is measured with a digital multimeter (DMM), while the high-frequency range is measured with a power meter.

1. As shown in the figure below, connect the SMB-BNC adaptor and the 50 Ω BNC feed-through load to the CH1 (+) port of DG6000 and use the BNC-single banana plug cable to connect the 50 Ω load and the voltage input terminal (HI) of the digital multimeter. Connect the SMB-BNC adaptor and the 50 Ω BNC feed-through load to the CH1 (-) port of DG6000 and use the BNC-single banana plug cable to connect the 50 Ω load and the voltage input terminal (LO) of the digital multimeter. This case takes CH1 as an example. The test method also applies to other channels.

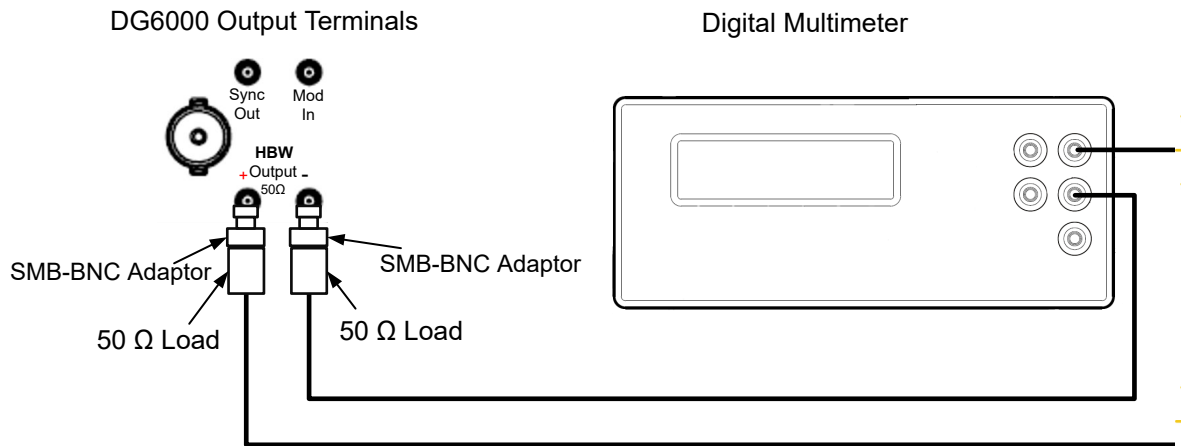

2. Press the front-panel **Default** key of DG6000 and a prompt message is displayed. Click or tap **OK** to restore the instrument to its factory default settings.
3. Configure DG6000:
 - a. Set the output type of CH1 to HBW (click or tap  > **Output Type** > **HBW**).
 - b. Set CH1 to output a Sine wave with 1 kHz frequency and 0 dBm amplitude range.
 - c. Turn on the output of CH1.
4. Select the AC voltage measurement function for the multimeter and enable the dBm operation. Set the reference resistance to 50 Ω and read the measured value as the reference power value (P_{ref1}).

TIP

In this step, if the dBm operation is not enabled, you can also use the measured value ($V_{Reading}$) on the multimeter and the formula " $dBm = 10 \times \lg[(V_{Reading}^2/R_{ref})/1 \text{ mW}]$ " to calculate the reference power value; wherein, R_{ref} is the load impedance.

5. Keep other settings unchanged for DG6000 and adjust the output frequency to 100 kHz. Record the measured value and verify that the "Measured Value- P_{ref1} " is between -0.1 dB and +0.1 dB.
6. Calibrate the power meter:
 - a. Press the front-panel **Preset/Local** key of the power sensor to restore the power sensor to its factory defaults.
 - b. Connect the power sensor to the input terminal and the **[POWER REF]** terminal of the power meter respectively.
 - c. Press the **Zero/Cal** key to open the Zero/Cal menu. Click or tap **Zero+Cal** to perform the calibration. After the calibration is complete, observe whether the measured value of the power meter is 0 dBm, 50 MHz.

7. Disconnect DG6000 and the multimeter. Use the SMB-N adaptor to connect the power sensor to the CH1 (+) port of DG6000 and then use the power meter cable to connect the power sensor output terminal to the power meter input terminal. Connect the 50 Ω SMB terminated load to the CH1 (-) port of DG6000, as shown in the figure below.

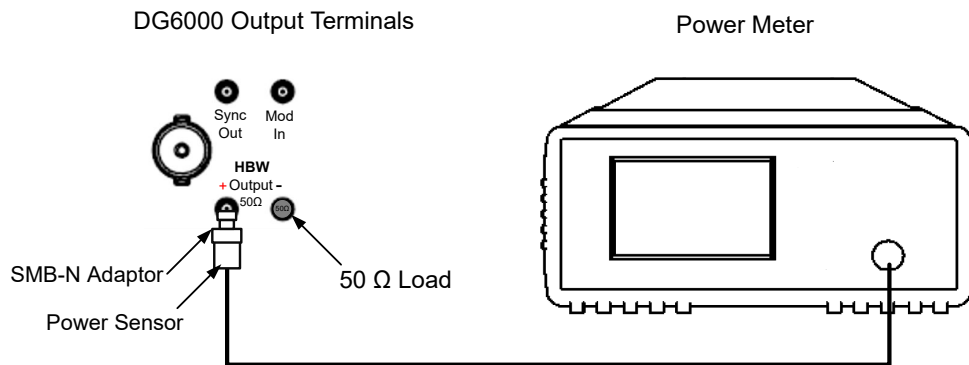

8. Keep other settings unchanged for DG6000 and adjust the output frequency to 1 MHz. Set the center frequency of the power meter to 1 MHz. Record the measured value of the power meter as the high-frequency range reference power value (P_{ref2}).
9. Keep other settings unchanged for DG6000 and adjust the output frequency to 2 MHz. Set the center frequency to 2 MHz for the power meter. Record the measured value and verify that the "Measured Value - P_{ref2} " is between -0.1 dB and +0.1 dB.
10. Keep other settings unchanged for DG6000 and adjust the output frequency to 5 MHz. Set the center frequency to 5 MHz for the power meter. Record the measured value and verify that the "Measured Value - P_{ref2} " is between -0.2 dB and +0.2 dB.
11. Keep other settings unchanged for DG6000 and adjust the output frequency to 50 MHz. Set the center frequency to 50 MHz for the power meter. Record the measured value and verify that the "Measured Value - P_{ref2} " is between -0.5 dB and +0.5 dB.
12. Keep other settings unchanged for DG6000 and adjust the output frequency to 100 MHz. Set the center frequency to 100 MHz for the power meter. Record the measured value and verify that the "Measured Value - P_{ref2} " is between -1.0 dB and +1.0 dB.
13. Keep other settings unchanged for DG6000 and adjust the output frequency to 200 MHz. Set the center frequency to 200 MHz for the power meter. Record the measured value and verify that the "Measured Value - P_{ref2} " is between -2.0 dB and +2.0 dB.
14. Keep other settings unchanged for DG6000 and adjust the output frequency to 500 MHz. Set the center frequency to 500 MHz for the power meter. Record the

measured value and verify that the "Measured Value - P_{ref2} " is between -2.0 dB and +2.0 dB.

15. Keep other settings unchanged for DG6000 and adjust the output frequency to 1 GHz (DG6102/DG6104 only). Set the center frequency to 1 GHz for the power meter. Record the measured value and verify that the "Measured Value - P_{ref2} " is between -2.0 dB and +2.0 dB.
16. Repeat the steps above to verify the AC flatness for other channels and record the test results.

4.4.3 Test Record Form

AC Flatness Test (SND)

Channel: CH1

P_{ref1} = _____ P_{ref2} = _____

Frequency Setting	Setting	Measured Value	Calculation Result ^[1]	Limit	Pass/Fail
100 kHz	Amplitude Range: 0 dBm Impedance: 50 Ω			± 0.1 dB	
2 MHz				± 0.1 dB	
5 MHz				± 0.2 dB	
50 MHz				± 0.5 dB	
100 MHz				± 1 dB	
200 MHz				± 2 dB	
500 MHz ^[2]				± 2 dB	

Channel: CH2

P_{ref1} = _____ P_{ref2} = _____

Frequency Setting	Setting	Measured Value	Calculation Result ^[1]	Limit	Pass/Fail
100 kHz	Amplitude Range: 0 dBm Impedance: 50 Ω			± 0.1 dB	
2 MHz				± 0.1 dB	
5 MHz				± 0.2 dB	
50 MHz				± 0.5 dB	
100 MHz				± 1 dB	

Frequency Setting	Setting	Measured Value	Calculation Result ^[1]	Limit	Pass/Fail
200 MHz				±2 dB	
500 MHz ^[2]				±2 dB	

Channel: CH3

 $P_{\text{ref1}} = \underline{\hspace{2cm}}$ $P_{\text{ref2}} = \underline{\hspace{2cm}}$

Frequency Setting	Setting	Measured Value	Calculation Result ^[1]	Limit	Pass/Fail
100 kHz	Amplitude Range: 0 dBm Impedance: 50 Ω			±0.1 dB	
2 MHz				±0.1 dB	
5 MHz				±0.2 dB	
50 MHz				±0.5 dB	
100 MHz				±1 dB	
200 MHz				±2 dB	
500 MHz ^[2]				±2 dB	

Channel: CH4

 $P_{\text{ref1}} = \underline{\hspace{2cm}}$ $P_{\text{ref2}} = \underline{\hspace{2cm}}$

Frequency Setting	Setting	Measured Value	Calculation Result ^[1]	Limit	Pass/Fail
100 kHz	Amplitude Range: 0 dBm Impedance: 50 Ω			±0.1 dB	
2 MHz				±0.1 dB	
5 MHz				±0.2 dB	
50 MHz				±0.5 dB	
100 MHz				±1 dB	
200 MHz				±2 dB	
500 MHz ^[2]				±2 dB	

Channel: CH5

 $P_{\text{ref1}} = \underline{\hspace{2cm}}$ $P_{\text{ref2}} = \underline{\hspace{2cm}}$

Frequency Setting	Setting	Measured Value	Calculation Result ^[1]	Limit	Pass/Fail
100 kHz	Amplitude Range: 0 dBm Impedance: 50 Ω			±0.1 dB	
2 MHz				±0.1 dB	
5 MHz				±0.2 dB	
50 MHz				±0.5 dB	
100 MHz				±1 dB	
200 MHz				±2 dB	
500 MHz ^[2]				±2 dB	

Channel: CH6

 $P_{ref1} = \underline{\hspace{2cm}}$ $P_{ref2} = \underline{\hspace{2cm}}$

Frequency Setting	Setting	Measured Value	Calculation Result ^[1]	Limit	Pass/Fail
100 kHz	Amplitude Range: 0 dBm Impedance: 50 Ω			±0.1 dB	
2 MHz				±0.1 dB	
5 MHz				±0.2 dB	
50 MHz				±0.5 dB	
100 MHz				±1 dB	
200 MHz				±2 dB	
500 MHz ^[2]				±2 dB	

Channel: CH7

 $P_{ref1} = \underline{\hspace{2cm}}$ $P_{ref2} = \underline{\hspace{2cm}}$

Frequency Setting	Setting	Measured Value	Calculation Result ^[1]	Limit	Pass/Fail
100 kHz	Amplitude Range: 0 dBm Impedance: 50 Ω			±0.1 dB	
2 MHz				±0.1 dB	
5 MHz				±0.2 dB	
50 MHz				±0.5 dB	

Frequency Setting	Setting	Measured Value	Calculation Result ^[1]	Limit	Pass/Fail
100 MHz				±1 dB	
200 MHz				±2 dB	
500 MHz ^[2]				±2 dB	

Channel: CH8

$P_{ref1} = \underline{\hspace{2cm}}$ $P_{ref2} = \underline{\hspace{2cm}}$

Frequency Setting	Setting	Measured Value	Calculation Result ^[1]	Limit	Pass/Fail
100 kHz	Amplitude Range: 0 dBm Impedance: 50 Ω			±0.1 dB	
2 MHz				±0.1 dB	
5 MHz				±0.2 dB	
50 MHz				±0.5 dB	
100 MHz				±1 dB	
200 MHz				±2 dB	
500 MHz ^[2]				±2 dB	

Note[1]: For 100 kHz frequency, Calculation Result = Amplitude Range Measured Value - P_{ref1} ; for other frequencies, Calculation Result = Amplitude Range Measured Value - P_{ref2} .

Note^[2]: for DG6102/DG6104 only.

AC Flatness Test (HBW)

Channel: CH1

$P_{ref1} = \underline{\hspace{2cm}}$ $P_{ref2} = \underline{\hspace{2cm}}$

Frequency Setting	Setting	Measured Value	Calculation Result ^[1]	Limit	Pass/Fail
100 kHz	Amplitude Range: 0 dBm			±0.1 dB	
2 MHz				±0.1 dB	
5 MHz				±0.2 dB	
50 MHz				±0.5 dB	
100 MHz				±1 dB	

Frequency Setting	Setting	Measured Value	Calculation Result ^[1]	Limit	Pass/Fail
200 MHz				±2 dB	
500 MHz				±2 dB	
1 GHz ^[2]				±2 dB	

Channel: CH2

 $P_{ref1} = \underline{\hspace{2cm}}$ $P_{ref2} = \underline{\hspace{2cm}}$

Frequency Setting	Setting	Measured Value	Calculation Result ^[1]	Limit	Pass/Fail
100 kHz	Amplitude Range: 0 dBm			±0.1 dB	
2 MHz				±0.1 dB	
5 MHz				±0.2 dB	
50 MHz				±0.5 dB	
100 MHz				±1 dB	
200 MHz				±2 dB	
500 MHz				±2 dB	
1 GHz ^[2]				±2 dB	

Channel: CH3

 $P_{ref1} = \underline{\hspace{2cm}}$ $P_{ref2} = \underline{\hspace{2cm}}$

Frequency Setting	Setting	Measured Value	Calculation Result ^[1]	Limit	Pass/Fail
100 kHz	Amplitude Range: 0 dBm			±0.1 dB	
2 MHz				±0.1 dB	
5 MHz				±0.2 dB	
50 MHz				±0.5 dB	
100 MHz				±1 dB	
200 MHz				±2 dB	
500 MHz				±2 dB	

Frequency Setting	Setting	Measured Value	Calculation Result ^[1]	Limit	Pass/Fail
1 GHz ^[2]				±2 dB	

Channel: CH4

$P_{ref1} = \underline{\hspace{2cm}}$ $P_{ref2} = \underline{\hspace{2cm}}$

Frequency Setting	Setting	Measured Value	Calculation Result ^[1]	Limit	Pass/Fail
100 kHz	Amplitude Range: 0 dBm			±0.1 dB	
2 MHz				±0.1 dB	
5 MHz				±0.2 dB	
50 MHz				±0.5 dB	
100 MHz				±1 dB	
200 MHz				±2 dB	
500 MHz				±2 dB	
1 GHz ^[2]					±2 dB

Note^[1]: For 100 kHz frequency, Calculation Result = Amplitude Range Measured Value - P_{ref1} ; for other frequencies, Calculation Result = Amplitude Range Measured Value - P_{ref2} .

Note^[2]: for DG6102/DG6104 only.

4.5 Harmonic Distortion Test

4.5.1 Specification

Sine Wave Spectral Purity	
Harmonic Distortion	Typical (0 dBm) 10 Hz to <10 MHz: <-70 dBc ≥10 MHz to <50 MHz: <-55 dBc ≥50 MHz to <200 MHz: <-45 dBc ≥200 MHz: <-35 dBc ≥500 MHz to <10000 MHz: <-25 dBc

4.5.2 Test Procedures

1. As shown in the figure below, use the dual BNC cable and the BNC-N adaptor to connect the output terminal of DG6000 to the RF input terminal of the spectrum analyzer. This case takes CH1 as an example. The test method also applies to other channels.

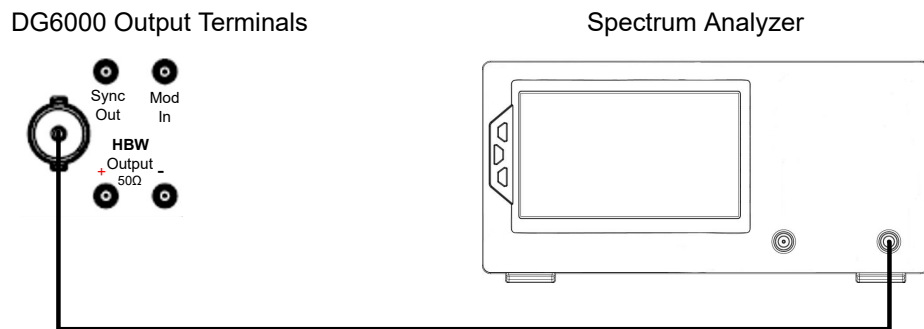

2. Press the front-panel **Default** key of DG6000 and a prompt message is displayed. Click or tap **OK** to restore the instrument to its factory default settings.
3. Configure DG6000:
 - a. Set the output type of CH1 to SND (click or tap  > **Output Type** > **SND**).
 - b. Set the output impedance of CH1 to 50 Ω (in CH1 setup interface, click or tap the **Channel** tab and select "Load" in the drop-down menu of **Imped**).
 - c. Set CH1 to output a Sine wave with 1 MHz frequency, 0 dBm amplitude range, and 0 Vdc offset.
 - d. Turn on the output of CH1.
4. Set up the spectrum analyzer:
 - a. Set the input attenuation to 20 dB and the reference level to 10 dBm.
 - b. Set the start frequency to 0 Hz and the stop frequency to 5 MHz.
 - c. Set the resolution bandwidth to 1 kHz.
5. Enable the peak table function of the spectrum analyzer and record the measured values of the fundamental wave and the second harmonic. Verify that the harmonic distortion is less than -60 dBc through calculation^[1].
6. Keep other settings unchanged for DG6000 and adjust the output frequency to 10 MHz.
7. Set up the spectrum analyzer:
 - a. Set the input attenuation to 20 dB and the reference level to 10 dBm.
 - b. Set the start frequency to 5 MHz and the stop frequency to 30 MHz.

- c. Set the resolution bandwidth to 1 kHz.
8. Record the measured values of the fundamental wave and the second harmonic.
Verify that the harmonic distortion is less than -50 dBc through calculation^[1].
9. Keep other settings unchanged for DG6000 and adjust the output frequency to 50 MHz.
10. Set up the spectrum analyzer:
 - a. Set the input attenuation to 20 dB and the reference level to 10 dBm.
 - b. Set the start frequency to 40 MHz and the stop frequency to 120 MHz.
 - c. Set the resolution bandwidth to 3 kHz.
11. Record the measured values of the fundamental wave and the second harmonic in the peak table. Verify that the harmonic distortion is less than -45 dBm through calculation^[1].
12. Keep other settings unchanged for DG6000 and adjust the output frequency to 200 MHz.
13. Set up the spectrum analyzer:
 - a. Set the input attenuation to 20 dB and the reference level to 10 dBm.
 - b. Set the start frequency to 150 MHz and the stop frequency to 500 MHz.
 - c. Set the resolution bandwidth to 3 kHz.
14. Record the measured values of the fundamental wave and the second harmonic in the peak table. Verify that the harmonic distortion is less than -35 dBc through calculation^[1].
15. Keep other settings unchanged for DG6000 and adjust the output frequency to 400 MHz.
16. Set up the spectrum analyzer:
 - a. Set the input attenuation to 20 dB and the reference level to 10 dBm.
 - b. Set the start frequency to 350 MHz and the stop frequency to 1 GHz.
 - c. Set the resolution bandwidth to 3 kHz.
17. Record the measured values of the fundamental wave and the second harmonic in the peak table. Verify that the harmonic distortion is less than -35 dBc through calculation^[1].
18. Repeat the steps above to verify the harmonic distortion for other channels and record the test results.

**NOTE**

[1]: The Second Harmonic Distortion = Measured Value of the Second Harmonic - Measured Value of the Fundamental Wave; For example, if the measured value of the fundamental wave is -10 dBm and the measured value of the second harmonic is -72 dBm, the second harmonic distortion = $(-72) - (-10) = -62$ dBc.

4.5.3 Test Record Form

Harmonic Distortion Test

Channel: CH1

Frequency Setting	Setting	Measured Value	Calculation Result ^[1]	Limit	Pass/Fail
1 MHz	Waveform: Sine Amplitude Range: 0 dBm Offset: 0 Vdc	1 (Fundamental Wave):		<-70 dBc	
		2:			
10 MHz		1 (Fundamental Wave):		<-55 dBc	
		2:			
50 MHz		1 (Fundamental Wave):		<-45 dBc	
		2:			
200 MHz		1 (Fundamental Wave):		<-35 dBc	
		2:			
400 MHz ^[2]	1 (Fundamental Wave):		<-35 dBc		
	2:				

Channel: CH2

Frequency Setting	Setting	Measured Value	Calculation Result ^[1]	Limit	Pass/Fail
1 MHz	Waveform: Sine Amplitude Range: 0 dBm Offset: 0 Vdc	1 (Fundamental Wave):		<-70 dBc	
		2:			
10 MHz		1 (Fundamental Wave):		<-55 dBc	
		2:			
50 MHz		1 (Fundamental Wave):		<-45 dBc	
		2:			
200 MHz		1 (Fundamental Wave):		<-35 dBc	
		2:			
400 MHz ^[2]	1 (Fundamental Wave):		<-35 dBc		
	2:				

Channel: CH3

Frequency Setting	Setting	Measured Value	Calculation Result ^[1]	Limit	Pass/Fail
1 MHz	Waveform: Sine Amplitude Range: 0 dBm Offset: 0 Vdc	1 (Fundamental Wave):		<-70 dBc	
		2:			
10 MHz		1 (Fundamental Wave):		<-55 dBc	
		2:			

Frequency Setting	Setting	Measured Value	Calculation Result ^[1]	Limit	Pass/Fail
50 MHz		1 (Fundamental Wave):		< -45 dBc	
		2:			
200 MHz		1 (Fundamental Wave):		< -35 dBc	
		2:			
400 MHz ^[2]		1 (Fundamental Wave):		< -35 dBc	
		2:			

Channel: CH4

Frequency Setting	Setting	Measured Value	Calculation Result ^[1]	Limit	Pass/Fail
1 MHz	Waveform: Sine Amplitude Range: 0 dBm Offset: 0 Vdc	1 (Fundamental Wave):		< -70 dBc	
		2:			
10 MHz		1 (Fundamental Wave):		< -55 dBc	
		2:			
50 MHz		1 (Fundamental Wave):		< -45 dBc	
		2:			
200 MHz	1 (Fundamental Wave):		< -35 dBc		
	2:				

Frequency Setting	Setting	Measured Value	Calculation Result ^[1]	Limit	Pass/Fail	
400 MHz ^[2]		1 (Fundamental Wave):		<-35 dBc		
		2:				

Channel: CH5

Frequency Setting	Setting	Measured Value	Calculation Result ^[1]	Limit	Pass/Fail	
1 MHz	Waveform: Sine Amplitude Range: 0 dBm Offset: 0 Vdc	1 (Fundamental Wave):		<-70 dBc		
		2:				
10 MHz		1 (Fundamental Wave):		<-55 dBc		
		2:				
50 MHz		1 (Fundamental Wave):		<-45 dBc		
		2:				
200 MHz	1 (Fundamental Wave):		<-35 dBc			
	2:					
400 MHz ^[2]	1 (Fundamental Wave):		<-35 dBc			
	2:					

Channel: CH6

Frequency Setting	Setting	Measured Value	Calculation Result ^[1]	Limit	Pass/Fail
1 MHz	Waveform: Sine Amplitude Range: 0 dBm Offset: 0 Vdc	1 (Fundamental Wave):		< -70 dBc	
		2:			
10 MHz		1 (Fundamental Wave):		< -55 dBc	
		2:			
50 MHz		1 (Fundamental Wave):		< -45 dBc	
		2:			
200 MHz	1 (Fundamental Wave):		< -35 dBc		
	2:				
400 MHz ^[2]	1 (Fundamental Wave):		< -35 dBc		
	2:				

Channel: CH7

Frequency Setting	Setting	Measured Value	Calculation Result ^[1]	Limit	Pass/Fail
1 MHz	Waveform: Sine Amplitude Range: 0 dBm Offset: 0 Vdc	1 (Fundamental Wave):		< -70 dBc	
		2:			
10 MHz		1 (Fundamental Wave):		< -55 dBc	
		2:			

Frequency Setting	Setting	Measured Value	Calculation Result ^[1]	Limit	Pass/Fail
50 MHz		1 (Fundamental Wave):		<-45 dBc	
		2:			
200 MHz		1 (Fundamental Wave):		<-35 dBc	
		2:			
400 MHz ^[2]		1 (Fundamental Wave):		<-35 dBc	
		2:			

Channel: CH8

Frequency Setting	Setting	Measured Value	Calculation Result ^[1]	Limit	Pass/Fail
1 MHz	Waveform: Sine Amplitude Range: 0 dBm Offset: 0 Vdc	1 (Fundamental Wave):		<-70 dBc	
		2:			
10 MHz		1 (Fundamental Wave):		<-55 dBc	
		2:			
50 MHz		1 (Fundamental Wave):		<-45 dBc	
		2:			
200 MHz		1 (Fundamental Wave):		<-35 dBc	
		2:			

Frequency Setting	Setting	Measured Value	Calculation Result ^[1]	Limit	Pass/Fail	
400 MHz ^[2]		1 (Fundamental Wave):		<-35 dBc		
		2:				

Note^[1]: Calculation Result = Measured Value for the nth Harmonic – Measured Value for the Fundamental Wave.

Note^[2]: for DG6102/DG6104 only.

4.6 Spurious Signal Test

4.6.1 Specification

Sine Wave Spurious Signal (nonharmonic)	
Specification	Typical (0 dBm) 10 Hz to <10 MHz: <-65 dBc ≥10 MHz to <50 MHz: <-60 dBc ≥50 MHz to 1000 MHz: <-50 dBc + 6 dBc/octave ^[1]

Note^[1]: 6 dBc/octave means that for every doubling of the frequency, the specification increases by 6 dBc. For example, when DG6000 outputs 50 MHz, the specification limit is -50 dBc; when it outputs 100 MHz, the limit is -50 dBc + 6 dBc.

4.6.2 Test Procedures

Test Procedures

- As shown in the figure below, use the dual BNC cable and the BNC-N adaptor to connect the output terminal of DG6000 to the RF input terminal of the spectrum analyzer. This case takes CH1 as an example. The test method also applies to other channels.

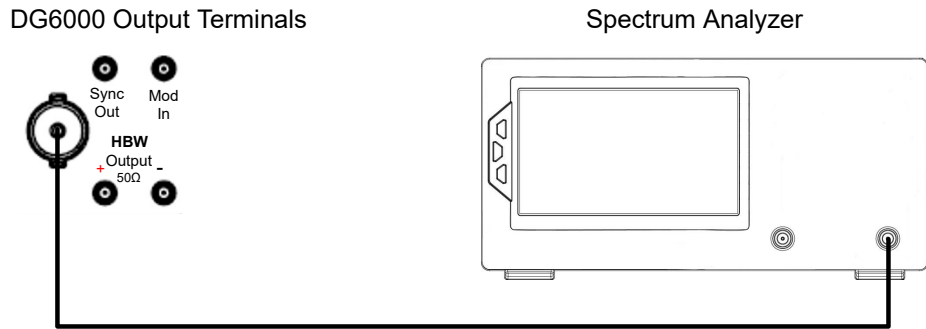

2. Press the front-panel **Default** key of DG6000 and a prompt message is displayed. Click or tap **OK** to restore the instrument to its factory default settings.
3. Configure DG6000:
 - a. Set the output type of CH1 to SND (click or tap > **Output Type** > **SND**).
 - b. Set the output impedance of CH1 to 50 Ω (in CH1 setup interface, click or tap the **Channel** tab and select "Load" in the drop-down menu of **Imped**).
 - c. Set CH1 to output a Sine wave with 1 MHz frequency, 0 dBm amplitude range, and 0 Vdc offset.
 - d. Turn on the output of CH1.
4. Set up the spectrum analyzer:
 - a. Set the reference level to 10 dBm and the input attenuation to 20 dB.
 - b. Set the start frequency to 0 Hz and the stop frequency to 10 MHz.
 - c. Set the resolution bandwidth to 1 kHz.
 - d. Set the peak shift to 3 dB.
 - e. Set the sweep mode to Single.
 - f. Press the front panel **Peak** key to find the maximum peak.
5. Measure the maximum spurious signal (except the harmonics) using the cursor measurement and record the test result A. Calculate the nonharmonic spurious signal (A - 0 dBm) and compare it with the specification.
6. Keep the other settings unchanged and change the output frequency of DG6000 and the stop frequency of the spectrum analyzer according to the table below. Record the max. spurious signal for each output frequency and calculate the measurement result. Compare the result with the specification.

DG6000 Output Frequency	Spectrum Analyzer Stop Frequency
10 MHz	100 MHz

DG6000 Output Frequency	Spectrum Analyzer Stop Frequency
50 MHz	150 MHz
200 MHz	500 MHz
400 MHz	1 GHz

7. Repeat the steps above to verify the spurious signal for other channels and record the test result.

4.6.3 Test Record Form

Spurious Signal Test

Channel: CH1

Output Frequency	Start Frequency	Stop Frequency	A	A - 0 dBm	Limit	Pass/Fail
1 MHz	0 Hz	10 MHz			<-65 dBc	
10 MHz	0 Hz	100 MHz			<-60 dBc	
50 MHz	0 Hz	150 MHz			<-50 dBc	
200 MHz	0 Hz	500 MHz			<-32 dBc	
400 MHz ^[1]	0 Hz	1 GHz			<-8 dBc	

Channel: CH2

Output Frequency	Start Frequency	Stop Frequency	A	A - 0 dBm	Limit	Pass/Fail
1 MHz	0 Hz	10 MHz			<-65 dBc	
10 MHz	0 Hz	100 MHz			<-60 dBc	
50 MHz	0 Hz	150 MHz			<-50 dBc	
200 MHz	0 Hz	500 MHz			<-32 dBc	
400 MHz ^[1]	0 Hz	1 GHz			<-8 dBc	

Channel: CH3

Output Frequency	Start Frequency	Stop Frequency	A	A - 0 dBm	Limit	Pass/Fail
1 MHz	0 Hz	10 MHz			<-65 dBc	

Output Frequency	Start Frequency	Stop Frequency	A	A - 0 dBm	Limit	Pass/Fail
10 MHz	0 Hz	100 MHz			<-60 dBc	
50 MHz	0 Hz	150 MHz			<-50 dBc	
200 MHz	0 Hz	500 MHz			<-32 dBc	
400 MHz ^[1]	0 Hz	1 GHz			<-8 dBc	

Channel: CH4

Output Frequency	Start Frequency	Stop Frequency	A	A - 0 dBm	Limit	Pass/Fail
1 MHz	0 Hz	10 MHz			<-65 dBc	
10 MHz	0 Hz	100 MHz			<-60 dBc	
50 MHz	0 Hz	150 MHz			<-50 dBc	
200 MHz	0 Hz	500 MHz			<-32 dBc	
400 MHz ^[1]	0 Hz	1 GHz			<-8 dBc	

Channel: CH5

Output Frequency	Start Frequency	Stop Frequency	A	A - 0 dBm	Limit	Pass/Fail
1 MHz	0 Hz	10 MHz			<-65 dBc	
10 MHz	0 Hz	100 MHz			<-60 dBc	
50 MHz	0 Hz	150 MHz			<-50 dBc	
200 MHz	0 Hz	500 MHz			<-32 dBc	
400 MHz ^[1]	0 Hz	1 GHz			<-8 dBc	

Channel: CH6

Output Frequency	Start Frequency	Stop Frequency	A	A - 0 dBm	Limit	Pass/Fail
1 MHz	0 Hz	10 MHz			<-65 dBc	
10 MHz	0 Hz	100 MHz			<-60 dBc	
50 MHz	0 Hz	150 MHz			<-50 dBc	
200 MHz	0 Hz	500 MHz			<-32 dBc	

Output Frequency	Start Frequency	Stop Frequency	A	A - 0 dBm	Limit	Pass/Fail
400 MHz ^[1]	0 Hz	1 GHz			<-8 dBc	

Channel: CH7

Output Frequency	Start Frequency	Stop Frequency	A	A - 0 dBm	Limit	Pass/Fail
1 MHz	0 Hz	10 MHz			<-65 dBc	
10 MHz	0 Hz	100 MHz			<-60 dBc	
50 MHz	0 Hz	150 MHz			<-50 dBc	
200 MHz	0 Hz	500 MHz			<-32 dBc	
400 MHz ^[1]	0 Hz	1 GHz			<-8 dBc	

Channel: CH8

Output Frequency	Start Frequency	Stop Frequency	A	A - 0 dBm	Limit	Pass/Fail
1 MHz	0 Hz	10 MHz			<-65 dBc	
10 MHz	0 Hz	100 MHz			<-60 dBc	
50 MHz	0 Hz	150 MHz			<-50 dBc	
200 MHz	0 Hz	500 MHz			<-32 dBc	
400 MHz ^[1]	0 Hz	1 GHz			<-8 dBc	

Note^[1]: for DG6102/DG6104 only.

4.7 Rise/Fall Time Test

4.7.1 Specification

Square Rise/Fall Time	
Specification	Typical (0 dBm amplitude range, 120 MHz frequency, 50 Ω load) Fast transition disabled: ≤ 1.4 ns (HBW)

4.7.2 Test Procedures

Test Procedures (HBW)

- As shown in the figure below, use the SMB-BNC cable to connect the CH1 (+) port of DG6000 to the CH1/CDR- input terminal of the oscilloscope. Connect the 50 Ω SMB load to the CH1 (-) port of DG6000. This case takes CH1 as an example. The test method also applies to other channels.

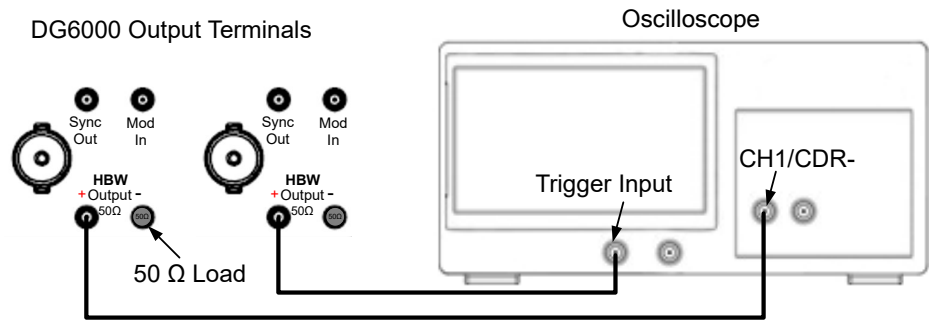

- Press the front-panel **Default** key of DG6000 and a prompt message is displayed. Click or tap **OK** to restore the instrument to its factory default settings.

- Configure DG6000:
 - Set the output type of CH1 to HBW (click or tap  > **Output Type** > **HBW**).
 - Set CH1 to output a Square wave with 120 MHz frequency and 0 dBm amplitude range, and disable the fast transition function.
 - Turn on the output of CH1.

- As shown in the figure above, connect the the CH2 (+) port of DG6000 to the Trigger Input terminal of the oscilloscope. Set the CH2 of DG6000 to output a Square wave with 10 MHz frequency and 0 dBm amplitude range, and disable the fast transition function.

NOTE

Since the 86108B module's CDR is not used and an external trigger is applied instead, to ensure trigger stability, the test output channel and the trigger-signal output channel must be on the same mainframe.

- Configure the oscilloscope:
 - Set the vertical scale to 200 mV/div.
 - Set the horizontal timebase to 2 ns.
 - Configure the trigger channel (press the front-panel Trigger Level knob and select the Front Panel input source). Set the trigger source to front-panel trigger input, and adjust the appropriate trigger level to a stable trigger.
 - Set the input impedance to 50 Ω .



- e. Enable the rise time and fall time measurement functions.
6. Set the edge type to rising edge for the oscilloscope. Record the measured value of the rise time and verify that the value is within the specified range.
7. Set the edge type to falling edge for the oscilloscope. Record the measured value of the fall time and verify that the value is within the specified range.
8. Repeat the steps above to test the rise/fall time for other channels and record the test results.

4.7.3 Test Record Form

Rise/Fall Time Test (HBW)

Channel: CH1

Setting	Measured Value		Limit	Pass/Fail	
Waveform: Square	Rise Time		≤ 1.4 ns		
Frequency: 120 MHz	Fall Time		≤ 1.4 ns		
Amplitude Range: 0 dBm					
Fast transition: off					

Channel: CH2

Setting	Measured Value		Limit	Pass/Fail	
Waveform: Square	Rise Time		≤ 1.4 ns		
Frequency: 120 MHz	Fall Time		≤ 1.4 ns		
Amplitude Range: 0 dBm					
Fast transition: off					

Channel: CH3

Setting	Measured Value		Limit	Pass/Fail	
Waveform: Square	Rise Time		≤ 1.4 ns		

Setting	Measured Value	Limit	Pass/Fail
Frequency: 120 MHz Amplitude Range: 0 dBm Fast transition: off	Fall Time	≤1.4 ns	

Channel: CH4

Setting	Measured Value	Limit	Pass/Fail
Waveform: Square Frequency: 120 MHz Amplitude Range: 0 dBm Fast transition: off	Rise Time	≤1.4 ns	
	Fall Time	≤1.4 ns	

4.8 Overshoot Test

4.8.1 Specification

Square Overshoot	
Specification	Typical (0 dBm amplitude range, 10 MHz frequency), <5% (fast transition disabled)

4.8.2 Test Procedures

Test Procedures (SND)

- As shown in the figure below, use the cable to connect the output terminal of DG6000 to the CH1/CDR- input terminal of the DCA-X86100D oscilloscope. This case takes CH1 as an example. The test method also applies to other channels. Please note that you need to prepare adapter cables and a 2.92mm dual female connector for direct adapter to BNC-SMA and SMB-SMA. To protect the sampling oscilloscope, it is recommended to install a 3 dB or 6 dB fixed attenuator at the oscilloscope input.

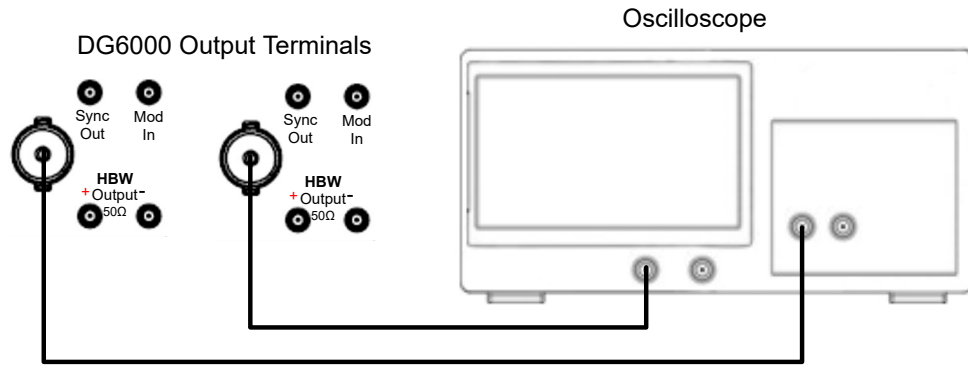

2. Press the front-panel **Default** key of DG6000 and a prompt message is displayed. Click or tap **OK** to restore the instrument to its factory default settings.
3. Configure DG6000:
 - a. Set the output type of CH1 to SND (click or tap  > **Output Type** > **SND**).
 - b. Set the output impedance of CH1 to 50 Ω (in CH1 setup interface, click or tap the **Channel** tab and select "Load" in the drop-down menu of **Imped**).
 - c. Set the CH1 to output a Square wave with 10 MHz frequency, 0 dBm amplitude range, and 0 Vdc offset, and disable the fast transition function.
 - d. Turn on the output of CH1.
4. As shown in the figure above, use the cable to connect the the CH2 output terminal of DG6000 to the Trigger Input terminal of the oscilloscope. Set the CH2 of DG6000 to output a Square wave with 10 MHz frequency, 0 dBm amplitude range, and 0 Vdc offset, and disable the fast transition function.



NOTE

Since the 86108B module's CDR is not used and an external trigger is applied instead, to ensure trigger stability, the test output channel and the trigger-signal output channel must be on the same mainframe.

5. Configure the oscilloscope:
 - a. Set the vertical scale to 200 mV/div.
 - b. Set the horizontal timebase to 2 ns.
 - c. Configure the trigger channel (press the front-panel Trigger Level knob and select the Front Panel input source). Set the trigger source to front-panel trigger input, and adjust the appropriate trigger level to a stable trigger.
 - d. Set the input impedance to 50 Ω .
 - e. Enable the overshoot measurement function.
6. Record the measured value of the oscilloscope and verify that the value is within the specified range.

- Repeat the steps above to verify the overshoot for other channels and record the test results.

Test Procedures (HBW)

- As shown in the figure below, use the SMB-BNC cable to connect the CH1 (+) port of DG6000 to the CH1/CDR- input terminal of the oscilloscope. Connect the 50 Ω SMB load to the CH1 (-) port of DG6000. This case takes CH1 as an example. The test method also applies to other channels.

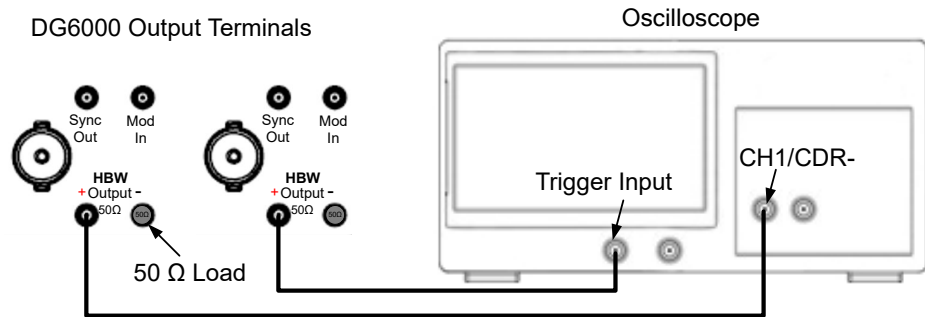

- Press the front-panel **Default** key of DG6000 and a prompt message is displayed. Click or tap **OK** to restore the instrument to its factory default settings.
- Configure DG6000:
 - Set the output type of CH1 to HBW (click or tap  > **Output Type** > **HBW**).
 - Set CH1 to output a Square wave with 10 MHz frequency and 0 dBm amplitude range, and disable the fast transition function.
 - Turn on the output of CH1.
- As shown in the figure above, connect the the CH2 (+) port of DG6000 to the Trigger Input terminal of the oscilloscope. Set the CH2 of DG6000 to output a Square wave with 10 MHz frequency and 0 dBm amplitude range, and disable the fast transition function.



NOTE

Since the 86108B module's CDR is not used and an external trigger is applied instead, to ensure trigger stability, the test output channel and the trigger-signal output channel must be on the same mainframe.

- Configure the oscilloscope:
 - Set the vertical scale to 200 mV/div.
 - Set the horizontal timebase to 2 ns.
 - Configure the trigger channel (press the front-panel Trigger Level knob and select the Front Panel input source). Set the trigger source to front-panel trigger input, and adjust the appropriate trigger level to a stable trigger.

- d. Set the input impedance to 50 Ω .
 - e. Enable the overshoot measurement function.
6. Record the measured value of the oscilloscope and verify that the value is within the specified range.
 7. Repeat the steps above to verify the overshoot for other channels and record the test results.

4.8.3 Test Record Form

Overshoot Test (SND)

Channel: CH1

Setting	Measured Value	Limit	Pass/ Fail
Waveform: Square Frequency: 10 MHz Amplitude Range: 0 dBm Offset: 0 Vdc		<5%	

Channel: CH2

Setting	Measured Value	Limit	Pass/ Fail
Waveform: Square Frequency: 10 MHz Amplitude Range: 0 dBm Offset: 0 Vdc		<5%	

Channel: CH3

Setting	Measured Value	Limit	Pass/ Fail
Waveform: Square Frequency: 10 MHz Amplitude Range: 0 dBm Offset: 0 Vdc		<5%	

Channel: CH4

Setting	Measured Value	Limit	Pass/ Fail
Waveform: Square Frequency: 10 MHz Amplitude Range: 0 dBm Offset: 0 Vdc		<5%	

Channel: CH5

Setting	Measured Value	Limit	Pass/ Fail
Waveform: Square Frequency: 10 MHz Amplitude Range: 0 dBm Offset: 0 Vdc		<5%	

Channel: CH6

Setting	Measured Value	Limit	Pass/ Fail
Waveform: Square Frequency: 10 MHz Amplitude Range: 0 dBm Offset: 0 Vdc		<5%	

Channel: CH7

Setting	Measured Value	Limit	Pass/ Fail
Waveform: Square Frequency: 10 MHz Amplitude Range: 0 dBm Offset: 0 Vdc		<5%	

Channel: CH8

Setting	Measured Value	Limit	Pass/ Fail
Waveform: Square		<5%	

Setting	Measured Value	Limit	Pass/ Fail
Frequency: 10 MHz Amplitude Range: 0 dBm Offset: 0 Vdc			

Overshoot Test (HBW)

Channel: CH1

Setting	Measured Value	Limit	Pass/ Fail
Waveform: Square Frequency: 10 MHz Amplitude Range: 0 dBm Offset: 0 Vdc		<5%	

Channel: CH2

Setting	Measured Value	Limit	Pass/ Fail
Waveform: Square Frequency: 10 MHz Amplitude Range: 0 dBm Offset: 0 Vdc		<5%	

Channel: CH3

Setting	Measured Value	Limit	Pass/ Fail
Waveform: Square Frequency: 10 MHz Amplitude Range: 0 dBm Offset: 0 Vdc		<5%	

Channel: CH4

Setting	Measured Value	Limit	Pass/ Fail
Waveform: Square Frequency: 10 MHz Amplitude Range: 0 dBm Offset: 0 Vdc		<5%	

5 Appendix: Test Record Form

RIGOL DG6000 Function/Arbitrary Waveform Generator Performance Verification Test Record Form

Model: _____ Tested by: _____ Test Date: _____

Frequency Accuracy Test

Channel: CH1

Waveform	Setting	Measured Value	Limit ^[1]	Pass/Fail
Sine	Frequency: 1 MHz Amplitude Range: 1 Vpp		0.999999 MHz to 1.000001 MHz	
Square			0.999999 MHz to 1.000001 MHz	
Ramp			0.999999 MHz to 1.000001 MHz	
Pulse			0.999999 MHz to 1.000001 MHz	
Harmonic			0.999999 MHz to 1.000001 MHz	

Channel: CH2

Waveform	Setting	Measured Value	Limit ^[1]	Pass/Fail
Sine	Frequency: 1 MHz Amplitude Range: 1 Vpp		0.999999 MHz to 1.000001 MHz	
Square			0.999999 MHz to 1.000001 MHz	
Ramp			0.999999 MHz to 1.000001 MHz	
Pulse			0.999999 MHz to 1.000001 MHz	
Harmonic			0.999999 MHz to 1.000001 MHz	

Channel: CH3

Waveform	Setting	Measured Value	Limit ^[1]	Pass/Fail
Sine	Frequency: 1 MHz		0.999999 MHz to 1.000001 MHz	
Square			0.999999 MHz to 1.000001 MHz	
Ramp			0.999999 MHz to 1.000001 MHz	

Waveform	Setting	Measured Value	Limit ^[1]	Pass/Fail
Pulse	Amplitude Range: 1 Vpp		0.999999 MHz to 1.000001 MHz	
Harmonic			0.999999 MHz to 1.000001 MHz	

Channel: CH4

Waveform	Setting	Measured Value	Limit ^[1]	Pass/Fail
Sine	Frequency: 1 MHz Amplitude Range: 1 Vpp		0.999999 MHz to 1.000001 MHz	
Square			0.999999 MHz to 1.000001 MHz	
Ramp			0.999999 MHz to 1.000001 MHz	
Pulse			0.999999 MHz to 1.000001 MHz	
Harmonic			0.999999 MHz to 1.000001 MHz	

Channel: CH5

Waveform	Setting	Measured Value	Limit ^[1]	Pass/Fail
Sine	Frequency: 1 MHz Amplitude Range: 1 Vpp		0.999999 MHz to 1.000001 MHz	
Square			0.999999 MHz to 1.000001 MHz	
Ramp			0.999999 MHz to 1.000001 MHz	
Pulse			0.999999 MHz to 1.000001 MHz	
Harmonic			0.999999 MHz to 1.000001 MHz	

Channel: CH6

Waveform	Setting	Measured Value	Limit ^[1]	Pass/Fail
Sine	Frequency: 1 MHz Amplitude Range: 1 Vpp		0.999999 MHz to 1.000001 MHz	
Square			0.999999 MHz to 1.000001 MHz	
Ramp			0.999999 MHz to 1.000001 MHz	
Pulse			0.999999 MHz to 1.000001 MHz	
Harmonic			0.999999 MHz to 1.000001 MHz	

Channel: CH7

Waveform	Setting	Measured Value	Limit ^[1]	Pass/Fail
Sine	Frequency: 1 MHz Amplitude Range: 1 Vpp		0.999999 MHz to 1.000001 MHz	
Square			0.999999 MHz to 1.000001 MHz	
Ramp			0.999999 MHz to 1.000001 MHz	
Pulse			0.999999 MHz to 1.000001 MHz	
Harmonic			0.999999 MHz to 1.000001 MHz	

Channel: CH8

Waveform	Setting	Measured Value	Limit ^[1]	Pass/Fail
Sine	Frequency: 1 MHz Amplitude Range: 1 Vpp		0.999999 MHz to 1.000001 MHz	
Square			0.999999 MHz to 1.000001 MHz	
Ramp			0.999999 MHz to 1.000001 MHz	
Pulse			0.999999 MHz to 1.000001 MHz	
Harmonic			0.999999 MHz to 1.000001 MHz	

Note^[1]: The limit is calculated from the frequency setting value (1 MHz) \pm permissible error. The permissible error is the setting value of $\pm 10^{-6}$ (except Arb), 0°C to 50°C.

AC Amplitude Range Accuracy Test (SND)

Channel: CH1

Amplitude Range Setting	Setting	Measured Value	Limit ^[1]	Pass/Fail
20 mVpp	Frequency: 1 kHz Offset: 0 Vdc Impedance: 50 Ω		6.6 mVrms to 7.5 mVrms	
100 mVpp			34.6 mVrms to 36.1 mVrms	
500 mVpp			174.7 mVrms to 178.9 mVrms	
1 Vpp			349.7 mVrms to 357.4 mVrms	
5 Vpp			1.7497Vrms to 1.7857 Vrms	

Amplitude Range Setting	Setting	Measured Value	Limit ^[1]	Pass/Fail
10 Vpp			3.4998 mVrms to 3.5712 mVrms	

Channel: CH2

Amplitude Range Setting	Setting	Measured Value	Limit ^[1]	Pass/Fail
20 mVpp	Frequency: 1 kHz Offset: 0 Vdc Impedance: 50 Ω		6.6 mVrms to 7.5 mVrms	
100 mVpp			34.6 mVrms to 36.1 mVrms	
500 mVpp			174.7 mVrms to 178.9 mVrms	
1 Vpp			349.7 mVrms to 357.4 mVrms	
5 Vpp			1.7497Vrms to 1.7857 Vrms	
10 Vpp			3.4998 mVrms to 3.5712 mVrms	

Channel: CH3

Amplitude Range Setting	Setting	Measured Value	Limit ^[1]	Pass/Fail
20 mVpp	Frequency: 1 kHz Offset: 0 Vdc Impedance: 50 Ω		6.6 mVrms to 7.5 mVrms	
100 mVpp			34.6 mVrms to 36.1 mVrms	
500 mVpp			174.7 mVrms to 178.9 mVrms	
1 Vpp			349.7 mVrms to 357.4 mVrms	
5 Vpp			1.7497Vrms to 1.7857 Vrms	
10 Vpp			3.4998 mVrms to 3.5712 mVrms	

Channel: CH4

Amplitude Range Setting	Setting	Measured Value	Limit ^[1]	Pass/Fail
20 mVpp	Frequency: 1 kHz Offset: 0 Vdc Impedance: 50 Ω		6.6 mVrms to 7.5 mVrms	
100 mVpp			34.6 mVrms to 36.1 mVrms	
500 mVpp			174.7 mVrms to 178.9 mVrms	
1 Vpp			349.7 mVrms to 357.4 mVrms	
5 Vpp			1.7497Vrms to 1.7857 Vrms	
10 Vpp			3.4998 mVrms to 3.5712 mVrms	

Channel: CH5

Amplitude Range Setting	Setting	Measured Value	Limit ^[1]	Pass/Fail
20 mVpp	Frequency: 1 kHz Offset: 0 Vdc Impedance: 50 Ω		6.6 mVrms to 7.5 mVrms	
100 mVpp			34.6 mVrms to 36.1 mVrms	
500 mVpp			174.7 mVrms to 178.9 mVrms	
1 Vpp			349.7 mVrms to 357.4 mVrms	
5 Vpp			1.7497Vrms to 1.7857 Vrms	
10 Vpp			3.4998 mVrms to 3.5712 mVrms	

Channel: CH6

Amplitude Range Setting	Setting	Measured Value	Limit ^[1]	Pass/Fail
20 mVpp	Frequency: 1 kHz Offset: 0 Vdc Impedance: 50 Ω		6.6 mVrms to 7.5 mVrms	
100 mVpp			34.6 mVrms to 36.1 mVrms	
500 mVpp			174.7 mVrms to 178.9 mVrms	

Amplitude Range Setting	Setting	Measured Value	Limit ^[1]	Pass/Fail
1 Vpp			349.7 mVrms to 357.4 mVrms	
5 Vpp			1.7497Vrms to 1.7857 Vrms	
10 Vpp			3.4998 mVrms to 3.5712 mVrms	

Channel: CH7

Amplitude Range Setting	Setting	Measured Value	Limit ^[1]	Pass/Fail
20 mVpp	Frequency: 1 kHz Offset: 0 Vdc Impedance: 50 Ω		6.6 mVrms to 7.5 mVrms	
100 mVpp			34.6 mVrms to 36.1 mVrms	
500 mVpp			174.7 mVrms to 178.9 mVrms	
1 Vpp			349.7 mVrms to 357.4 mVrms	
5 Vpp			1.7497Vrms to 1.7857 Vrms	
10 Vpp			3.4998 mVrms to 3.5712 mVrms	

Channel: CH8

Amplitude Range Setting	Setting	Measured Value	Limit ^[1]	Pass/Fail
20 mVpp	Frequency: 1 kHz Offset: 0 Vdc Impedance: 50 Ω		6.6 mVrms to 7.5 mVrms	
100 mVpp			34.6 mVrms to 36.1 mVrms	
500 mVpp			174.7 mVrms to 178.9 mVrms	
1 Vpp			349.7 mVrms to 357.4 mVrms	
5 Vpp			1.7497Vrms to 1.7857 Vrms	

Amplitude Range Setting	Setting	Measured Value	Limit ^[1]	Pass/Fail
10 Vpp			3.4998 mVrms to 3.5712 mVrms	

Note^[1]: 1 kHz Sine, amplitude range > 1 mVpp, 0 Vdc offset, unit: Vpp. $\pm(1\%$ of the setting value + 1 mVpp).

AC Amplitude Range Accuracy Test (HBW)

Channel: CH1

Amplitude Range Setting	Setting	Measured Value	Limit ^[1]	Pass/Fail
400 mVpp	Frequency: 1 kHz Impedance: 50 Ω		6.6 mVrms to 7.5 mVrms	
1 Vpp			34.6 mVrms to 36.1 mVrms	
1.4 Vpp			174.7 mVrms to 178.9 mVrms	
2 Vpp			349.7 mVrms to 357.4 mVrms	

Channel: CH2

Amplitude Range Setting	Setting	Measured Value	Limit ^[1]	Pass/Fail
400 mVpp	Frequency: 1 kHz Offset: 0 Vdc Impedance: 50 Ω		6.6 mVrms to 7.5 mVrms	
1 Vpp			34.6 mVrms to 36.1 mVrms	
1.4 Vpp			174.7 mVrms to 178.9 mVrms	
2 Vpp			349.7 mVrms to 357.4 mVrms	

Channel: CH3

Amplitude Range Setting	Setting	Measured Value	Limit ^[1]	Pass/Fail
400 mVpp	Frequency: 1 kHz		6.6 mVrms to 7.5 mVrms	
1 Vpp			34.6 mVrms to 36.1 mVrms	

Amplitude Range Setting	Setting	Measured Value	Limit ^[1]	Pass/Fail
1.4 Vpp	Impedance: 50 Ω		174.7 mVrms to 178.9 mVrms	
2 Vpp			349.7 mVrms to 357.4 mVrms	

Channel: CH4

Amplitude Range Setting	Setting	Measured Value	Limit ^[1]	Pass/Fail
400 mVpp	Frequency: 1 kHz Impedance: 50 Ω		6.6 mVrms to 7.5 mVrms	
1 Vpp			34.6 mVrms to 36.1 mVrms	
1.4 Vpp			174.7 mVrms to 178.9 mVrms	
2 Vpp			349.7 mVrms to 357.4 mVrms	

Note^[1]: 1 kHz Sine, amplitude range >400 mVpp, unit: Vpp. ±(1% of the setting value + 1 mVpp).

DC Offset Accuracy Test (SND)

Channel: CH1

Offset Setting	Setting	Measured Value	Limit ^[1]	Pass/Fail
-2.5 Vdc	Frequency: 1 kHz Amplitude Range: 5 Vpp Impedance: 50 Ω		-2.551 Vdc to -2.449 Vdc	
-1 Vdc			-1.036 Vdc to -0.964 Vdc	
-500 mVdc			-0.531 Vdc to -0.469 Vdc	
0 Vdc			-0.026 Vdc to +0.026 Vdc	
+500 mVdc			0.469 Vdc to 0.531 Vdc	
+1 Vdc			0.964 Vdc to 1.036 Vdc	
+2.5 Vdc			2.449 Vdc to 2.551 Vdc	

Channel: CH2

Offset Setting	Setting	Measured Value	Limit ^[1]	Pass/Fail
-2.5 Vdc	Frequency: 1 kHz Amplitude Range: 5 Vpp Impedance: 50 Ω		-2.551 Vdc to -2.449 Vdc	
-1 Vdc			-1.036 Vdc to -0.964 Vdc	
-500 mVdc			-0.531 Vdc to -0.469 Vdc	
0 Vdc			-0.026 Vdc to +0.026 Vdc	
+500 mVdc			0.469 Vdc to 0.531 Vdc	
+1 Vdc			0.964 Vdc to 1.036 Vdc	
+2.5 Vdc			2.449 Vdc to 2.551 Vdc	

Channel: CH3

Offset Setting	Setting	Measured Value	Limit ^[1]	Pass/Fail
-2.5 Vdc	Frequency: 1 kHz Amplitude Range: 5 Vpp Impedance: 50 Ω		-2.551 Vdc to -2.449 Vdc	
-1 Vdc			-1.036 Vdc to -0.964 Vdc	
-500 mVdc			-0.531 Vdc to -0.469 Vdc	
0 Vdc			-0.026 Vdc to +0.026 Vdc	
+500 mVdc			0.469 Vdc to 0.531 Vdc	
+1 Vdc			0.964 Vdc to 1.036 Vdc	
+2.5 Vdc			2.449 Vdc to 2.551 Vdc	

Channel: CH4

Offset Setting	Setting	Measured Value	Limit ^[1]	Pass/Fail
-2.5 Vdc	Frequency: 1 kHz Amplitude Range: 5 Vpp Impedance: 50 Ω		-2.551 Vdc to -2.449 Vdc	
-1 Vdc			-1.036 Vdc to -0.964 Vdc	
-500 mVdc			-0.531 Vdc to -0.469 Vdc	
0 Vdc			-0.026 Vdc to +0.026 Vdc	
+500 mVdc			0.469 Vdc to 0.531 Vdc	
+1 Vdc			0.964 Vdc to 1.036 Vdc	

Offset Setting	Setting	Measured Value	Limit ^[1]	Pass/Fail	
+2.5 Vdc			2.449 Vdc to 2.551 Vdc		

Channel: CH5

Offset Setting	Setting	Measured Value	Limit ^[1]	Pass/Fail	
-2.5 Vdc	Frequency: 1 kHz Amplitude Range: 5 Vpp Impedance: 50 Ω		-2.551 Vdc to -2.449 Vdc		
-1 Vdc			-1.036 Vdc to -0.964 Vdc		
-500 mVdc			-0.531 Vdc to -0.469 Vdc		
0 Vdc			-0.026 Vdc to +0.026 Vdc		
+500 mVdc			0.469 Vdc to 0.531 Vdc		
+1 Vdc			0.964 Vdc to 1.036 Vdc		
+2.5 Vdc			2.449 Vdc to 2.551 Vdc		

Channel: CH6

Offset Setting	Setting	Measured Value	Limit ^[1]	Pass/Fail	
-2.5 Vdc	Frequency: 1 kHz Amplitude Range: 5 Vpp Impedance: 50 Ω		-2.551 Vdc to -2.449 Vdc		
-1 Vdc			-1.036 Vdc to -0.964 Vdc		
-500 mVdc			-0.531 Vdc to -0.469 Vdc		
0 Vdc			-0.026 Vdc to +0.026 Vdc		
+500 mVdc			0.469 Vdc to 0.531 Vdc		
+1 Vdc			0.964 Vdc to 1.036 Vdc		
+2.5 Vdc			2.449 Vdc to 2.551 Vdc		

Channel: CH7

Offset Setting	Setting	Measured Value	Limit ^[1]	Pass/Fail	
-2.5 Vdc	Frequency: 1 kHz Amplitude Range: 5 Vpp		-2.551 Vdc to -2.449 Vdc		
-1 Vdc			-1.036 Vdc to -0.964 Vdc		
-500 mVdc			-0.531 Vdc to -0.469 Vdc		

Offset Setting	Setting	Measured Value	Limit ^[1]	Pass/Fail
0 Vdc	Impedance: 50 Ω		-0.026 Vdc to +0.026 Vdc	
+500 mVdc			0.469 Vdc to 0.531 Vdc	
+1 Vdc			0.964 Vdc to 1.036 Vdc	
+2.5 Vdc			2.449 Vdc to 2.551 Vdc	

Channel: CH8

Offset Setting	Setting	Measured Value	Limit ^[1]	Pass/Fail
-2.5 Vdc	Frequency: 1 kHz Amplitude Range: 5 Vpp Impedance: 50 Ω		-2.551 Vdc to -2.449 Vdc	
-1 Vdc			-1.036 Vdc to -0.964 Vdc	
-500 mVdc			-0.531 Vdc to -0.469 Vdc	
0 Vdc			-0.026 Vdc to +0.026 Vdc	
+500 mVdc			0.469 Vdc to 0.531 Vdc	
+1 Vdc			0.964 Vdc to 1.036 Vdc	
+2.5 Vdc			2.449 Vdc to 2.551 Vdc	

Note^[1]: The offset limit value is calculated from the offset setting value \pm permissible error. The permissible error is calculated from the specification " $\pm(1\% \text{ of } |\text{the setting value}| + 1 \text{ mVdc} + 0.5\% \text{ of the amplitude (Vpp)})$ ".

DC Offset Accuracy Test (HBW)

Channel: CH1

Offset Setting	Amplitude Range Setting	Permissible Error ^[1]	Offset Limit
-200 mVdc	1 Vpp	± 7 mVdc	-207 mVdc to -193 mVdc
-100 mVdc		± 6 mVdc	-106 mVdc to -94 mVdc
0 Vdc		± 5 mVdc	-5 mVdc to +5 mVdc
+100 mVdc		± 6 mVdc	+94 mVdc to +106 mVdc
+200 mVdc		± 7 mVdc	+193 mVdc to +207 mVdc

Channel: CH2

Offset Setting	Amplitude Range Setting	Permissible Error ^[1]	Offset Limit
-200 mVdc	1 Vpp	±7 mVdc	-207 mVdc to -193 mVdc
-100 mVdc		±6 mVdc	-106 mVdc to -94 mVdc
0 Vdc		±5 mVdc	-5 mVdc to +5 mVdc
+100 mVdc		±6 mVdc	+94 mVdc to +106 mVdc
+200 mVdc		±7 mVdc	+193 mVdc to +207 mVdc

Channel: CH3

Offset Setting	Amplitude Range Setting	Permissible Error ^[1]	Offset Limit
-200 mVdc	1 Vpp	±7 mVdc	-207 mVdc to -193 mVdc
-100 mVdc		±6 mVdc	-106 mVdc to -94 mVdc
0 Vdc		±5 mVdc	-5 mVdc to +5 mVdc
+100 mVdc		±6 mVdc	+94 mVdc to +106 mVdc
+200 mVdc		±7 mVdc	+193 mVdc to +207 mVdc

Channel: CH4

Offset Setting	Amplitude Range Setting	Permissible Error ^[1]	Offset Limit
-200 mVdc	1 Vpp	±7 mVdc	-207 mVdc to -193 mVdc
-100 mVdc		±6 mVdc	-106 mVdc to -94 mVdc
0 Vdc		±5 mVdc	-5 mVdc to +5 mVdc
+100 mVdc		±6 mVdc	+94 mVdc to +106 mVdc
+200 mVdc		±7 mVdc	+193 mVdc to +207 mVdc

Note^[1]: The offset limit value is calculated from the offset setting value ± permissible error. The permissible error is calculated from the specification "±(1% of |the setting value| + 5 mV)".

AC Flatness Test (SND)

Channel: CH1

 $P_{ref1} = \underline{\hspace{2cm}}$ $P_{ref2} = \underline{\hspace{2cm}}$

Frequency Setting	Setting	Measured Value	Calculation Result ^[1]	Limit	Pass/Fail
100 kHz	Amplitude Range: 0 dBm Impedance: 50 Ω			± 0.1 dB	
2 MHz				± 0.1 dB	
5 MHz				± 0.2 dB	
50 MHz				± 0.5 dB	
100 MHz				± 1 dB	
200 MHz				± 2 dB	
500 MHz ^[2]				± 2 dB	

Channel: CH2

 $P_{ref1} = \underline{\hspace{2cm}}$ $P_{ref2} = \underline{\hspace{2cm}}$

Frequency Setting	Setting	Measured Value	Calculation Result ^[1]	Limit	Pass/Fail
100 kHz	Amplitude Range: 0 dBm Impedance: 50 Ω			± 0.1 dB	
2 MHz				± 0.1 dB	
5 MHz				± 0.2 dB	
50 MHz				± 0.5 dB	
100 MHz				± 1 dB	
200 MHz				± 2 dB	
500 MHz ^[2]				± 2 dB	

Channel: CH3

 $P_{ref1} = \underline{\hspace{2cm}}$ $P_{ref2} = \underline{\hspace{2cm}}$

Frequency Setting	Setting	Measured Value	Calculation Result ^[1]	Limit	Pass/Fail
100 kHz	Amplitude Range: 0 dBm			± 0.1 dB	
2 MHz				± 0.1 dB	

Frequency Setting	Setting	Measured Value	Calculation Result ^[1]	Limit	Pass/Fail
5 MHz	Impedance: 50 Ω			±0.2 dB	
50 MHz				±0.5 dB	
100 MHz				±1 dB	
200 MHz				±2 dB	
500 MHz ^[2]				±2 dB	

Channel: CH4

P_{ref1} = _____ P_{ref2} = _____

Frequency Setting	Setting	Measured Value	Calculation Result ^[1]	Limit	Pass/Fail
100 kHz	Amplitude Range: 0 dBm Impedance: 50 Ω			±0.1 dB	
2 MHz				±0.1 dB	
5 MHz				±0.2 dB	
50 MHz				±0.5 dB	
100 MHz				±1 dB	
200 MHz				±2 dB	
500 MHz ^[2]				±2 dB	

Channel: CH5

P_{ref1} = _____ P_{ref2} = _____

Frequency Setting	Setting	Measured Value	Calculation Result ^[1]	Limit	Pass/Fail
100 kHz	Amplitude Range: 0 dBm Impedance: 50 Ω			±0.1 dB	
2 MHz				±0.1 dB	
5 MHz				±0.2 dB	
50 MHz				±0.5 dB	
100 MHz				±1 dB	
200 MHz				±2 dB	

Frequency Setting	Setting	Measured Value	Calculation Result ^[1]	Limit	Pass/Fail
500 MHz ^[2]				±2 dB	

Channel: CH6

 $P_{ref1} = \underline{\hspace{2cm}}$ $P_{ref2} = \underline{\hspace{2cm}}$

Frequency Setting	Setting	Measured Value	Calculation Result ^[1]	Limit	Pass/Fail
100 kHz	Amplitude Range: 0 dBm Impedance: 50 Ω			±0.1 dB	
2 MHz				±0.1 dB	
5 MHz				±0.2 dB	
50 MHz				±0.5 dB	
100 MHz				±1 dB	
200 MHz				±2 dB	
500 MHz ^[2]				±2 dB	

Channel: CH7

 $P_{ref1} = \underline{\hspace{2cm}}$ $P_{ref2} = \underline{\hspace{2cm}}$

Frequency Setting	Setting	Measured Value	Calculation Result ^[1]	Limit	Pass/Fail
100 kHz	Amplitude Range: 0 dBm Impedance: 50 Ω			±0.1 dB	
2 MHz				±0.1 dB	
5 MHz				±0.2 dB	
50 MHz				±0.5 dB	
100 MHz				±1 dB	
200 MHz				±2 dB	
500 MHz ^[2]				±2 dB	

Channel: CH8

 $P_{ref1} = \underline{\hspace{2cm}}$ $P_{ref2} = \underline{\hspace{2cm}}$

Frequency Setting	Setting	Measured Value	Calculation Result ^[1]	Limit	Pass/Fail
100 kHz	Amplitude Range: 0 dBm Impedance: 50 Ω			±0.1 dB	
2 MHz				±0.1 dB	
5 MHz				±0.2 dB	
50 MHz				±0.5 dB	
100 MHz				±1 dB	
200 MHz				±2 dB	
500 MHz ^[2]				±2 dB	

Note^[1]: For 100 kHz, Calculation Result = Amplitude Range Measured Value - P_{ref1} ;
for other frequencies, Calculation Result = Amplitude Range Measured Value - P_{ref2} .

Note^[2]: for DG6102/DG6104 only.

AC Flatness Test (HBW)

Channel: CH1

P_{ref1} = _____ P_{ref2} = _____

Frequency Setting	Setting	Measured Value	Calculation Result ^[1]	Limit	Pass/Fail
100 kHz	Amplitude Range: 0 dBm			±0.1 dB	
2 MHz				±0.1 dB	
5 MHz				±0.2 dB	
50 MHz				±0.5 dB	
100 MHz				±1 dB	
200 MHz				±2 dB	
500 MHz				±2 dB	
1 GHz ^[2]				±2 dB	

Channel: CH2

P_{ref1} = _____ P_{ref2} = _____

Frequency Setting	Setting	Measured Value	Calculation Result ^[1]	Limit	Pass/Fail
100 kHz	Amplitude Range: 0 dBm			±0.1 dB	
2 MHz				±0.1 dB	
5 MHz				±0.2 dB	
50 MHz				±0.5 dB	
100 MHz				±1 dB	
200 MHz				±2 dB	
500 MHz				±2 dB	
1 GHz ^[2]				±2 dB	

Channel: CH3

 $P_{\text{ref1}} = \underline{\hspace{2cm}}$ $P_{\text{ref2}} = \underline{\hspace{2cm}}$

Frequency Setting	Setting	Measured Value	Calculation Result ^[1]	Limit	Pass/Fail
100 kHz	Amplitude Range: 0 dBm			±0.1 dB	
2 MHz				±0.1 dB	
5 MHz				±0.2 dB	
50 MHz				±0.5 dB	
100 MHz				±1 dB	
200 MHz				±2 dB	
500 MHz				±2 dB	
1 GHz ^[2]				±2 dB	

Channel: CH4

 $P_{\text{ref1}} = \underline{\hspace{2cm}}$ $P_{\text{ref2}} = \underline{\hspace{2cm}}$

Frequency Setting	Setting	Measured Value	Calculation Result ^[1]	Limit	Pass/Fail
100 kHz	Amplitude Range: 0 dBm			±0.1 dB	
2 MHz				±0.1 dB	
5 MHz				±0.2 dB	

Frequency Setting	Setting	Measured Value	Calculation Result ^[1]	Limit	Pass/Fail
50 MHz				±0.5 dB	
100 MHz				±1 dB	
200 MHz				±2 dB	
500 MHz				±2 dB	
1 GHz ^[2]				±2 dB	

Note^[1]: For 100 kHz, Calculation Result = Amplitude Range Measured Value - P_{ref1} ;
for other frequencies, Calculation Result = Amplitude Range Measured Value - P_{ref2} .

Note^[2]: for DG6102/DG6104 only.

Harmonic Distortion Test

Channel: CH1

Frequency Setting	Setting	Measured Value	Calculation Result ^[1]	Limit	Pass/Fail
1 MHz	Waveform: Sine Amplitude Range: 0 dBm Offset: 0 Vdc	1 (Fundamental Wave):		<-70 dBc	
		2:			
10 MHz		1 (Fundamental Wave):		<-55 dBc	
		2:			
50 MHz		1 (Fundamental Wave):		<-45 dBc	
		2:			
200 MHz		1 (Fundamental Wave):		<-35 dBc	
		2:			

Frequency Setting	Setting	Measured Value	Calculation Result ^[1]	Limit	Pass/Fail	
400 MHz ^[2]		1 (Fundamental Wave):		<-35 dBc		
		2:				

Channel: CH2

Frequency Setting	Setting	Measured Value	Calculation Result ^[1]	Limit	Pass/Fail	
1 MHz	Waveform: Sine Amplitude Range: 0 dBm Offset: 0 Vdc	1 (Fundamental Wave):		<-70 dBc		
		2:				
10 MHz		1 (Fundamental Wave):		<-55 dBc		
		2:				
50 MHz		1 (Fundamental Wave):		<-45 dBc		
		2:				
200 MHz	1 (Fundamental Wave):		<-35 dBc			
	2:					
400 MHz ^[2]	1 (Fundamental Wave):		<-35 dBc			
	2:					

Channel: CH3

Frequency Setting	Setting	Measured Value	Calculation Result ^[1]	Limit	Pass/Fail
1 MHz	Waveform: Sine Amplitude Range: 0 dBm Offset: 0 Vdc	1 (Fundamental Wave):		<-70 dBc	
		2:			
10 MHz		1 (Fundamental Wave):		<-55 dBc	
		2:			
50 MHz		1 (Fundamental Wave):		<-45 dBc	
		2:			
200 MHz		1 (Fundamental Wave):		<-35 dBc	
		2:			
400 MHz ^[2]	1 (Fundamental Wave):		<-35 dBc		
	2:				

Channel: CH4

Frequency Setting	Setting	Measured Value	Calculation Result ^[1]	Limit	Pass/Fail
1 MHz	Waveform: Sine Amplitude Range: 0 dBm Offset: 0 Vdc	1 (Fundamental Wave):		<-70 dBc	
		2:			
10 MHz		1 (Fundamental Wave):		<-55 dBc	
		2:			

Frequency Setting	Setting	Measured Value	Calculation Result ^[1]	Limit	Pass/Fail
50 MHz		1 (Fundamental Wave):		<-45 dBc	
		2:			
200 MHz		1 (Fundamental Wave):		<-35 dBc	
		2:			
400 MHz ^[2]		1 (Fundamental Wave):		<-35 dBc	
		2:			

Channel: CH5

Frequency Setting	Setting	Measured Value	Calculation Result ^[1]	Limit	Pass/Fail
1 MHz	Waveform: Sine Amplitude Range: 0 dBm Offset: 0 Vdc	1 (Fundamental Wave):		<-70 dBc	
		2:			
10 MHz		1 (Fundamental Wave):		<-55 dBc	
		2:			
50 MHz		1 (Fundamental Wave):		<-45 dBc	
		2:			
200 MHz		1 (Fundamental Wave):		<-35 dBc	
		2:			

Frequency Setting	Setting	Measured Value	Calculation Result ^[1]	Limit	Pass/Fail	
400 MHz ^[2]		1 (Fundamental Wave):		<-35 dBc		
		2:				

Channel: CH6

Frequency Setting	Setting	Measured Value	Calculation Result ^[1]	Limit	Pass/Fail	
1 MHz	Waveform: Sine Amplitude Range: 0 dBm Offset: 0 Vdc	1 (Fundamental Wave):		<-70 dBc		
		2:				
10 MHz		1 (Fundamental Wave):		<-55 dBc		
		2:				
50 MHz		1 (Fundamental Wave):		<-45 dBc		
		2:				
200 MHz	1 (Fundamental Wave):		<-35 dBc			
	2:					
400 MHz ^[2]	1 (Fundamental Wave):		<-35 dBc			
	2:					

Channel: CH7

Frequency Setting	Setting	Measured Value	Calculation Result ^[1]	Limit	Pass/Fail
1 MHz	Waveform: Sine Amplitude Range: 0 dBm Offset: 0 Vdc	1 (Fundamental Wave):		<-70 dBc	
		2:			
10 MHz		1 (Fundamental Wave):		<-55 dBc	
		2:			
50 MHz		1 (Fundamental Wave):		<-45 dBc	
		2:			
200 MHz	1 (Fundamental Wave):		<-35 dBc		
	2:				
400 MHz ^[2]	1 (Fundamental Wave):		<-35 dBc		
	2:				

Channel: CH8

Frequency Setting	Setting	Measured Value	Calculation Result ^[1]	Limit	Pass/Fail
1 MHz	Waveform: Sine Amplitude Range: 0 dBm Offset: 0 Vdc	1 (Fundamental Wave):		<-70 dBc	
		2:			
10 MHz		1 (Fundamental Wave):		<-55 dBc	
		2:			

Frequency Setting	Setting	Measured Value	Calculation Result ^[1]	Limit	Pass/Fail	
50 MHz		1 (Fundamental Wave):		<-45 dBc		
		2:				
200 MHz		1 (Fundamental Wave):		<-35 dBc		
		2:				
400 MHz ^[2]		1 (Fundamental Wave):		<-35 dBc		
		2:				

Note^[1]: Calculation Result = Measured Value for the nth Harmonic – Measured Value for the Fundamental Wave.

Note^[2]: for DG6102/DG6104 only.

Spurious Signal Test

Channel: CH1

Output Frequency	Start Frequency	Stop Frequency	A	A - 0 dBm	Limit	Pass/Fail	
1 MHz	0 Hz	10 MHz			<-65 dBc		
10 MHz	0 Hz	100 MHz			<-60 dBc		
50 MHz	0 Hz	150 MHz			<-45 dBc		
200 MHz	0 Hz	500 MHz			<-27 dBc		
400 MHz ^[1]	0 Hz	1 GHz			<-3 dBc		

Channel: CH2

Output Frequency	Start Frequency	Stop Frequency	A	A - 0 dBm	Limit	Pass/Fail	
1 MHz	0 Hz	10 MHz			<-65 dBc		

Output Frequency	Start Frequency	Stop Frequency	A	A - 0 dBm	Limit	Pass/Fail
10 MHz	0 Hz	100 MHz			<-60 dBc	
50 MHz	0 Hz	150 MHz			<-45 dBc	
200 MHz	0 Hz	500 MHz			<-27 dBc	
400 MHz ^[1]	0 Hz	1 GHz			<-3 dBc	

Channel: CH3

Output Frequency	Start Frequency	Stop Frequency	A	A - 0 dBm	Limit	Pass/Fail
1 MHz	0 Hz	10 MHz			<-65 dBc	
10 MHz	0 Hz	100 MHz			<-60 dBc	
50 MHz	0 Hz	150 MHz			<-45 dBc	
200 MHz	0 Hz	500 MHz			<-27 dBc	
400 MHz ^[1]	0 Hz	1 GHz			<-3 dBc	

Channel: CH4

Output Frequency	Start Frequency	Stop Frequency	A	A - 0 dBm	Limit	Pass/Fail
1 MHz	0 Hz	10 MHz			<-65 dBc	
10 MHz	0 Hz	100 MHz			<-60 dBc	
50 MHz	0 Hz	150 MHz			<-45 dBc	
200 MHz	0 Hz	500 MHz			<-27 dBc	
400 MHz ^[1]	0 Hz	1 GHz			<-3 dBc	

Channel: CH5

Output Frequency	Start Frequency	Stop Frequency	A	A - 0 dBm	Limit	Pass/Fail
1 MHz	0 Hz	10 MHz			<-65 dBc	
10 MHz	0 Hz	100 MHz			<-60 dBc	
50 MHz	0 Hz	150 MHz			<-45 dBc	
200 MHz	0 Hz	500 MHz			<-27 dBc	

Output Frequency	Start Frequency	Stop Frequency	A	A - 0 dBm	Limit	Pass/Fail
400 MHz ^[1]	0 Hz	1 GHz			<-3 dBc	

Channel: CH6

Output Frequency	Start Frequency	Stop Frequency	A	A - 0 dBm	Limit	Pass/Fail
1 MHz	0 Hz	10 MHz			<-65 dBc	
10 MHz	0 Hz	100 MHz			<-60 dBc	
50 MHz	0 Hz	150 MHz			<-45 dBc	
200 MHz	0 Hz	500 MHz			<-27 dBc	
400 MHz ^[1]	0 Hz	1 GHz			<-3 dBc	

Channel: CH7

Output Frequency	Start Frequency	Stop Frequency	A	A - 0 dBm	Limit	Pass/Fail
1 MHz	0 Hz	10 MHz			<-65 dBc	
10 MHz	0 Hz	100 MHz			<-60 dBc	
50 MHz	0 Hz	150 MHz			<-45 dBc	
200 MHz	0 Hz	500 MHz			<-27 dBc	
400 MHz ^[1]	0 Hz	1 GHz			<-3 dBc	

Channel: CH8

Output Frequency	Start Frequency	Stop Frequency	A	A - 0 dBm	Limit	Pass/Fail
1 MHz	0 Hz	10 MHz			<-65 dBc	
10 MHz	0 Hz	100 MHz			<-60 dBc	
50 MHz	0 Hz	150 MHz			<-45 dBc	
200 MHz	0 Hz	500 MHz			<-27 dBc	
400 MHz ^[1]	0 Hz	1 GHz			<-3 dBc	

Note^[1]: for DG6102/DG6104 only.

Rise/Fall Time Test (HBW)

Channel: CH1

Setting	Measured Value	Limit	Pass/Fail
Waveform: Square	Rise Time	≤1.4 ns	
Frequency: 120 MHz Amplitude Range: 0 dBm Fast transition: off	Fall Time	≤1.4 ns	

Channel: CH2

Setting	Measured Value	Limit	Pass/Fail
Waveform: Square	Rise Time	≤1.4 ns	
Frequency: 120 MHz Amplitude Range: 0 dBm Fast transition: off	Fall Time	≤1.4 ns	

Channel: CH3

Setting	Measured Value	Limit	Pass/Fail
Waveform: Square	Rise Time	≤1.4 ns	
Frequency: 120 MHz Amplitude Range: 0 dBm Fast transition: off	Fall Time	≤1.4 ns	

Channel: CH4

Setting	Measured Value	Limit	Pass/Fail
Waveform: Square	Rise Time	≤1.4 ns	

Setting	Measured Value	Limit	Pass/Fail
Frequency: 120 MHz Amplitude Range: 0 dBm Fast transition: off	Fall Time	≤ 1.4 ns	

Overshoot Test (SND)

Channel: CH1

Setting	Measured Value	Limit	Pass/Fail
Waveform: Square Frequency: 10 MHz Amplitude Range: 0 dBm Offset: 0 Vdc		<5%	

Channel: CH2

Setting	Measured Value	Limit	Pass/Fail
Waveform: Square Frequency: 10 MHz Amplitude Range: 0 dBm Offset: 0 Vdc		<5%	

Channel: CH3

Setting	Measured Value	Limit	Pass/Fail
Waveform: Square Frequency: 10 MHz Amplitude Range: 0 dBm Offset: 0 Vdc		<5%	

Channel: CH4

Setting	Measured Value	Limit	Pass/ Fail
Waveform: Square Frequency: 10 MHz Amplitude Range: 0 dBm Offset: 0 Vdc		<5%	

Channel: CH5

Setting	Measured Value	Limit	Pass/ Fail
Waveform: Square Frequency: 10 MHz Amplitude Range: 0 dBm Offset: 0 Vdc		<5%	

Channel: CH6

Setting	Measured Value	Limit	Pass/ Fail
Waveform: Square Frequency: 10 MHz Amplitude Range: 0 dBm Offset: 0 Vdc		<5%	

Channel: CH7

Setting	Measured Value	Limit	Pass/ Fail
Waveform: Square Frequency: 10 MHz Amplitude Range: 0 dBm Offset: 0 Vdc		<5%	

Channel: CH8

Setting	Measured Value	Limit	Pass/ Fail
Waveform: Square		<5%	

Setting	Measured Value	Limit	Pass/ Fail
Frequency: 10 MHz Amplitude Range: 0 dBm Offset: 0 Vdc			

Overshoot Test (HBW)

Channel: CH1

Setting	Measured Value	Limit	Pass/ Fail
Waveform: Square Frequency: 10 MHz Amplitude Range: 0 dBm Offset: 0 Vdc		<5%	

Channel: CH2

Setting	Measured Value	Limit	Pass/ Fail
Waveform: Square Frequency: 10 MHz Amplitude Range: 0 dBm Offset: 0 Vdc		<5%	

Channel: CH3

Setting	Measured Value	Limit	Pass/ Fail
Waveform: Square Frequency: 10 MHz Amplitude Range: 0 dBm Offset: 0 Vdc		<5%	

Channel: CH4

Setting	Measured Value	Limit	Pass/ Fail
Waveform: Square Frequency: 10 MHz Amplitude Range: 0 dBm Offset: 0 Vdc		<5%	

Boost Smart World and Technology Innovation

Industrial Intelligent
Manufacturing



Semiconductors

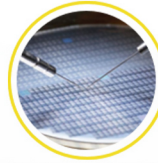

Education &
Research

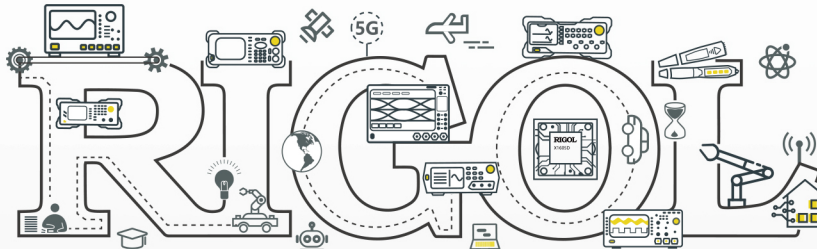

Communication

System Integration

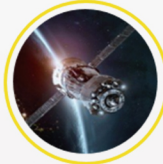

New Energy



- 5G Cellular-5G/WIFI
- UWB/RFID/ ZIGBEE
- Digital Bus/Ethernet
- Optical Communication

- Digital/Analog/RF Chip
- Memory and MCU Chip
- Third-Generation Semiconductor
- Solar Photovoltaic Cells

- New Energy Automobile
- PV/Inverter
- Power Test
- Automotive Electronics

*Provide Testing and Measuring Products
and Solutions for Industry Customers*

HEADQUARTER

RIGOL TECHNOLOGIES CO., LTD.
No.8 Keling Road, New District,
Suzhou, JiangSu, P.R.China
Tel: +86-400620002
Email: info-cn@rigol.com

JAPAN

RIGOL JAPAN CO., LTD.
5F, 3-45-6, Minamiotsuka, Toshima-Ku,
Tokyo, 170-0005, Japan
Tel: +81-3-6262-8932
Fax: +81-3-6262-8933
Email: info.jp@rigol.com

EUROPE

RIGOL TECHNOLOGIES EU GmbH
Friedrichshafener Str. 5
82205 Gilching
Germany
Tel: +49(0)8105-27292-21
Email: info-europe@rigol.com

KOREA

RIGOL KOREA CO., LTD.
5F, 222, Gonghang-daero,
Gangseo-gu, Seoul, Republic of Korea
Tel: +82-2-6953-4466
Fax: +82-2-6953-4422
Email: info.kr@rigol.com

NORTH AMERICA

RIGOL TECHNOLOGIES, USA INC.
10220 SW Nimbus Ave.
Suite K-7
Portland, OR 97223
Tel: +1-877-4-RIGOL-1
Email: sales@rigol.com

For Assistance in Other Countries

Email: info.int@rigol.com